

MAKING MODERN LIVING POSSIBLE



# Danfoss VLT Drives VLT<sup>®</sup> Product Catalogue



**50%**

**Energy saving**

Speed control of fans and pumps can in many cases lead to significant energy savings.

[www.danfoss.com/drives](http://www.danfoss.com/drives)

**VLT<sup>®</sup>**  
THE REAL DRIVE



# 33 million

tonnes annual CO<sub>2</sub> reduction

Today 3.5 million VLT® drives from Danfoss are installed worldwide and they save as much as 33 million tonnes of CO<sub>2</sub> every year<sup>1</sup> – corresponding to the CO<sub>2</sub> emissions from more than 11 million cars in Europe<sup>2</sup> or 17 million households<sup>3</sup>.

<sup>1</sup> Danfoss

<sup>2</sup> European Commission: Progress report on implementation of the Community's integrated approach to reduce CO<sub>2</sub> emissions from light-duty vehicles (2010)

– The average CO<sub>2</sub> emissions from EU cars in 2009 was 145,7 g CO<sub>2</sub>/km.

<sup>3</sup> EEA EN18 Electricity Consumption (2007): An EU household spends 5,100 kWh/year.

Based on emission factors in IEA's "CO<sub>2</sub> Emissions from Fuel Combustion (2006 Edition)", an EU household emits 5100 x 0,370 = 1,9 ton CO<sub>2</sub>/year.

# Helps you stay green, clean and efficient

The basic urge for Danfoss VLT Drives is to enable our customers to have easy and efficient control of any application powered by an AC motor.

Controlling an application – a fan, pump, compressor, centrifuge, hoist, etc. – via the power supply provides two important benefits:

- Fully automated operation
- Major energy savings

## Energy savings

Energy savings are tied to the technology and the fact that applications need less energy when idle or operating with partial loads.

VLT® drives do the trick – and no brand is more energy efficient than VLT® drives.

## Fully automated operation

VLT® drives enable a facility to increase its automation capabilities. Not every application is the same across all industries, but with VLT® drives customized programming, customers can determine what parameters are essential to their specific needs.

## One basic technology – millions of versions

That's why our customers always will ask for specific power sizes, features, enclosure classes and fieldbus protocols.

The VLT® concept is to mass produce such highly customised drives from a relatively limited number of components on stock.

## Factory built and tested

Having received an order – a drive specified by the customer – our factory builds it and tests it against real motors before shipping.

Factories and competence centres all around the globe, enables Danfoss VLT Drives to deliver drives that suits your purpose exactly – within a few days.

## Throughput modularity

This is possible due to throughput modularity in the design. Components developed for one drive can be mass produced and used in many different types of drives – and the same modularity allows for easy and quick updates and upgrades of your VLT® drive.

## Know one and you will know them all

The control panel is such an element. Knowing how to control one drive with the local control panel, you will be able to control all other VLT® drives. Embedded features and different plug-in options make the difference between the different versions.

This catalogue presents the majority of our different versions and describes how they are dedicated for specific industries and applications.



# Contents

PAGE 6



## VLT® AutomationDrive

The VLT® AutomationDrive is a single drive concept that covers the entire spectrum of drives applications – a major benefit in commissioning, operating and maintaining the equipment. VLT® AutomationDrive comes in a standard version (FC 301) and an advanced high dynamic version (FC 302) with additional functionalities.

PAGE 22



## VLT® Decentral Drive FCD 300

The VLT® FCD 300 is a complete frequency converter designed for decentral mounting. It can be mounted on the machine/wall – close to the motor – or directly onto the motor. The decentral design eliminates the need for space-consuming control cabinets and the need for long screened motor cables is significantly reduced.

PAGE 10



## VLT® HVAC Drive

The VLT® HVAC Drive continues Danfoss leadership in dedicated HVAC features and applications for drives. Advancements in energy monitoring, trending, system maintenance and operation are combined with a modular platform to make the drive easy to operate while feeding back all the operation information you need..

PAGE 24



## VLT® DriveMotor FCM 300

The VLT® FCM 300 Series is an integrated drive-motor solution which combines a VLT® frequency converter and a high standard quality induction motor in a single product. The frequency converter is attached in place of the motor terminal box and it is no higher than the standard terminal box – nor wider or longer than the motor.

PAGE 13



## VLT® AQUA Drive

VLT® AQUA Drive is the perfect match for pumps and blowers in modern water and wastewater systems, offering advanced application protective features. Available with cascade control of up to 8 pumps in fixed speed mode or master/follower mode.

PAGE 26



## VLT® OneGearDrive

The OneGearDrive™ is designed especially for use in the food and beverage industry. It comes in two versions, the HygienicDrive and the Standard version. The HygienicDrive is certified for use in clean rooms and the pharmaceutical industry. The compact construction of the OneGearDrive makes it especially suitable for mounting on transport and conveyor systems.

PAGE 16



## VLT® 2800 Series

An extremely compact series of drives designed for side-by-side mounting and developed specifically for the low power market.

PAGE 28



## VLT® Integrated Servo Drive

The new ISD 410 is a high performance Integrated Servo Drive system based on PM motor technology. The motion control is integrated in the drive. The communication bus is CAN. It is a system for applications with a variable number of axis and it allows flexible machine structure within food & beverage and packaging.

PAGE 18



## VLT® Micro Drive

A compact general purpose drive for AC motors up to 22 kW. It performs perfectly even in complex application set-ups and optimises energy efficiency and operation.

PAGE 30



## VLT® Soft Starter MCD 500

A total motor-starting solution with advanced start, stop and protection features, Adaptive Acceleration Control, inside delta connection, 4 line graphical display and multiple programming setup menus.

PAGE 20



## VLT® Decentral Drive FCD 302

The VLT® Decentral Drive FCD 302 is the new generation of the highly successful VLT® Decentral FCD 300, based on the VLT® AutomationDrive FC 302 platform. It combines the key features of both products in a completely re-designed enclosure, made for best fit on direct machine mounting.

PAGE 32



## VLT® Compact Starter MCD 200

The VLT® Compact Starter MCD 200 is a compact and cost effective soft starter range for applications where direct-on-line starting is undesirable. MCD 200 is, because of its size and functionality, a good alternative to other reduced voltage starting methods such as star/delta starters.



### VLT® Soft Starter MCD 100

The VLT® Soft Starter is a cost effective and extremely compact soft starter for AC motors from 1.1 – 11 kW. Due to a unique semiconductor design it is a true “fit and forget” product.



### VLT® Low Harmonic Drive

Meets the toughest harmonic requirements under all load/grid conditions. The Danfoss VLT® Low Harmonic Drive is the first solution combining an active filter and a drive in one package. The VLT® Low Harmonic Drive continuously regulates harmonic suppression according to the load and grid conditions without affecting the connected motor.



### VLT® 12-Pulse Drives

A robust and cost effective harmonic solution for the higher power range. The Danfoss VLT® 12-pulse drive offers reduced harmonics for demanding industry applications above 250 kW. The VLT® 12-pulse is a high efficiency variable frequency converter which is built to the same modular design as the popular 6-pulse VLT® drives.



### VLT® Advanced Active Filter AAF 006

A flexible and adaptable solution for central or de-central harmonic mitigation. Danfoss Advanced Active Filters can compensate for individual VLT® drives as a compact integrated solution or can be installed as a compact stand-alone solution at a point of common coupling, compensating for multiple loads simultaneously. Danfoss Active Filters can operate at medium voltage level by means of a step-down transformer.



### VLT® Advanced Harmonic Filter AHF 005/010

The Danfoss Advanced Harmonic Filters have been specially designed to match the Danfoss frequency converters. The solution is available in two variants, AHF 005 and AHF 010, connected in front of a Danfoss frequency converter, the harmonic current distortion generated back to the mains is reduced to 5% and 10% Total Harmonic Current Distortion at full load.



### VLT® Common Mode Filters

Common mode filters are placed between the frequency converter and the motor. They are nano-crystalline cores that mitigate high frequency noise in the motor cable (shielded or unshielded) and reduce bearing currents in the motor.



### VLT® Sine-Wave Filters

Sine-wave filters are placed between the frequency converter and the motor. They are low-pass filters that suppress the switching frequency component from the frequency converter and smooth out the phase-to-phase output voltage of the frequency converter to make it sinusoidal. This reduces the motor insulation stress, bearing currents and eliminates the switching acoustic noise from the motor.



### VLT® dU/dt Filters

du/dt filters are placed between the frequency converter and the motor. They are differential-mode filters that reduce motor terminal phase-to-phase peak voltage spikes and reduce the rise time to a level that lowers the stress on the insulation of motor windings. du/dt filters are smaller, weigh less and have a lower price compared to sine-wave filters.



### VLT® Motion Control Tool MCT 10

For managing drive parameters in systems, the Motion Control Tool MCT 10 is the perfect tool to handle all drive-related data.



### VLT® MCT 31 Harmonics Calculation Software

With VLT® MCT 31, you can determine whether harmonics will be an issue in your installation when drives are added. VLT® MCT 31 estimates the benefits of adding various harmonic mitigation solutions from the Danfoss product portfolio and calculates system harmonic distortion.



### VLT® Energy Box

With VLT® Energy Box software you can both theoretically in project face estimate and afterwards physically validate your real energy savings and reductions in your carbon footprint – from your desk.



### VLT® Service – Your way

DrivePro™ is an efficient productivity programme tailored to meet your specific needs. All the necessary VLT® Service facilities are at your disposal, which will minimize downtime and increase productivity at your factory.

# VLT® AutomationDrive

## Perfect

match for:

- Industrial automation
- High dynamic applications
- Safety installations



The VLT® AutomationDrive is a single drive concept that covers an entire range of applications, which is a major benefit in commissioning, operating and maintaining the equipment.

The modular open-technology platform that VLT® AutomationDrive is built on makes it exceptionally adaptable and programmable. Its configurable, user-friendly interface supports local languages and letters.

### Pluggable options

The drive solution can be adapted to any application due to the flexible option structure. Numerous options are available and can be mounted and tested from factory or be plugged in later for change-over or upgrade.

### Adapts to the future

The modular concept of VLT® AutomationDrive makes it highly adaptable – also to future features and options. Modularity offers the benefit of buying on a need-to-have basis without losing future possibilities.

### Hot pluggable Control Panel

The Local Control Panel (LCP) can be plugged in directly or connected through a cable for remote commissioning. The LCP can be disconnected during operation and replaced with a

Feature	Benefit
<b>Reliable</b>	<b>Maximum uptime</b>
Ambient temperature 50° C without derating	Less need for cooling or oversizing
Available in IP 00, 20, 21, 54, 55 and 66 enclosures	Suitable for harsh and wash down areas
Resistant to wear and tear	Low lifetime cost
Back-channel cooling for frame D, E and F	Prolonged lifetime of electronics
<b>User-friendly</b>	<b>Saves commissioning and operating cost</b>
Plug-and-Play technology	Easy upgrade and change over
Awarded control panel	User-friendly
Intuitive VLT® interface	Saves time
Pluggable cage clamp connectors	Easy connection
Exchangeable languages	User-friendly
<b>Intelligent</b>	
Intelligent warning systems	Warning before controlled stop
Smart Logic Control	Reduces need for PLC capacity
Advanced plug-in features	Easy commissioning
Safe stop	Safety cat. 3 (EN 954-1), PL d (ISO 13849-1), Stop cat. 0 (EN 60204-1)
STO: Safe Torque Off (IEC 61800-5-2)	SIL 2 (IEC 61508) SIL CL 2 (IEC 62061)
Intelligent heat management	Intelligent heat management

blind cover. Settings are easily transferred via the LCP from one drive to another or from a PC to a drive with the VLT® Set-up Software MCT 10.

### Awarded

VLT® AutomationDrive has received the Frost & Sullivan award for innovation and the iF Design Award for its user-friendliness.

### Power range

3 x 200 – 240 V .....	0.25 – 37 kW
3 x 380 – 480/500 V .....	0.37 – 800 kW
3 x 525 – 600 V .....	0.75 kW – 75 kW
3 x 535 – 690 V .....	37 kW – 1200 kW
Normal overload .....	45 – 1400 kW

## Options

The following options are available:

### Fieldbus options

- MCA 101 Profibus
- MCA 104 DeviceNet
- MCA 105 CanOpen
- MCA 113 Profibus VLT® 3000 protocol converter
- MCA 114 Profibus VLT® 5000 protocol converter
- MCA 120 PROFINET
- MCA 121 Ethernet IP
- MCA 122 Modbus TCP

### I/O and feedback options

- MCB 101 General Purpose I/O
- MCB 102 Encoder
- MCB 103 Resolver
- MCB 105 Relay
- MCB 107 24 V input option for control voltage
- MCB 113 Extended Relay Card
- MCB 114 VLT® Sensor Input

### Safety options

- MCB 108 Safety PLC interface (DC/DC converter)
- MCB 112 ATEX-PTC Thermistor Card

### Brake chopper (IGBT) option

Connected to an external brake resistor, the built-in brake chopper limits the load on the intermediate circuit in the case the motor acts as a generator.

### Motion Control Options

- MCO 305 Programmable Motion Controller
- MCO 350 Synchronizing Controller
- MCO 351 Positioning Controller
- MCO 352 Center Winder Controller

### Power options

- Brake resistors
- Sine-Wave Filters
- dU/dt Filters
- Harmonic Filters (AHF)

## Specifications

Mains supply (L1, L2, L3)	
Supply voltage	200 – 240 V ±10% FC 301: 380 – 480 V ±10% FC 302: 380 – 500 V ±10%, 525 – 600 V ±10% 525 – 690 V ±10%
Supply frequency	50/60 Hz
True Power Factor (λ)	0.92 nominal at rated load
Displacement Power Factor (cos φ) near unity	(> 0.98)
Switching on input supply L1, L2, L3	Maximum 2 times/min.

Output data (U, V, W)	
Output voltage	0 – 100% of supply voltage
Output frequency	FC 301: 0.2 – 1000 Hz (0.25 – 75 kW) FC 302: 0 – 1000 Hz (0.25 – 75 kW) 0 – 800 Hz (90 – 1200 kW) 0 – 300 Hz (Flux mode)
Switching on output	Unlimited
Ramp times	1–3600 sec.

Note: 160% current can be provided for 1 minute.  
Higher overload rating is achieved by oversizing the drive.

Digital inputs	
Programmable digital inputs	FC 301: 4 (5) / FC 302: 4 (6)
Logic	PNP or NPN
Voltage level	0–24 VDC

Note: One/two digital inputs can be programmed as digital output for FC 301/FC 302.

Analogue input	
Analogue inputs	2
Modes	Voltage or current
Voltage level	FC 301: 0 to +10 V FC 302: -10 to +10 V (scaleable)
Current level	0/4 to 20 mA (scaleable)

Pulse/encoder inputs	
Programmable pulse/encoder inputs	FC 301: 1 / FC 302: 2
Voltage level	0 – 24 V DC (PNP positive logic)

Digital output*	
Programmable digital/pulse outputs	FC 301: 1 / FC 302: 2
Voltage level at digital/frequency output	0 – 24 V

Analogue output*	
Programmable analogue outputs	1
Current range	0/4 – 20 mA

Relay outputs*	
Programmable relay outputs	FC 301: 1 / FC 302: 2

Cable lengths	
Max. motor cable lengths	FC 301: 50 m / FC 302: 150 m (screened/armoured) FC 301: 75 m / FC 302: 300 m (unscreened/unarmoured)

\*More analogue and digital inputs/outputs can be added by options.

### Other accessories

- IP 21/NEMA 1 Kit (convert IP 20 to IP 21)
- PROFIBUS adapter
- Sub-D9 Connector
- Decoupling plate for fieldbus cables
- USB connection cable to PC
- Panel Through option
- LCP panel mounting kit
- Mounting brackets
- Mains disconnect option

### High power options

- IEC Emergency stop with Safety Relay
- Safety Stop with Safety Relay
- RFI Filters
- NAMUR terminals
- RCD
- IRM
- Mains shielding
- Regen terminals

Please see the VLT® High Power Drive Selection Guide for the complete range of options.

Current and power ratings

FC 300	kW		T2 200 – 240 V						T4/T5 380 – 480/500 V											
			Amp.		IP 20	IP 21	IP 55	IP 66	Amp. HO		Amp. NO		IP 00	IP 20	IP 21	IP 54	IP 55	IP 66		
	HO	NO	HO	NO					≤440 V	>440 V	≤440 V	>440 V								
PK25	0.25		1.8																	
PK37	0.37		2.4						1.3	1.2	1.3	1.2								
PK55	0.55		3.5						1.8	1.6	1.8	1.6								
PK75	0.75		4.6						2.4	2.1	2.4	2.1								
P1K1	1.1		6.6						3	2.7	3	2.7								
P1K5	1.5		7.5						4.1	3.4	4.1	3.4								
P2K2	2.2		10.6						5.6	4.8	5.6	4.8								
P3K0	3		12.5						7.2	6.3	7.2	6.3								
P3K7	3.7		16.7																	
P4K0	4.0								10	8.2	10	8.2								
P5K5	5.5	7.5	24.2	30.8					13	11	13	11								
P7K5	7.5	11	30.8	46.2					16	14.5	16	14.5								
P11K	11	15	46.2	59.4					24	21	32	27								
P15K	15	18	59.4	74.8					32	27	37.5	34								
P18K	18.5	22	74.8	88					37.5	34	44	40								
P22K	22	30	88	115					44	40	61	52								
P30K	30	37	115	143					61	52	73	65								
P37K	37	45	143	170					73	65	90	80								
P45K	45	55							90	80	106	105								
P55K	55	75							106	105	147	130								
P75K	75	90							147	130	177	160								
P90K	90	110							177	160	212	190								
P110	110	132							212	190	260	240								
P132	132	160							260	240	315	302								
P160	160	200							315	302	395	361								
P200	200	250							395	361	480	443								
P250	250	315							480	443	600	540								
P315	315	400							600	540	658	590								
P355	355	450							658	590	745	678								
P400	400	500							695	678	800	730								
P450	450	500							800	730	880	780								
P500	500	560							880	780	990	890								
P560	560	630							990	890	1120	1050								
P630	630	710							1120	1050	1260	1160								
P710	710	800							1260	1160	1460	1380								
P800	800	1000							1460	1380	1700	1530								
P900	900	1000																		
P1M0	1000	1200																		
P1M2	1200	1400																		
P1M4	Consult factory																			
P1M6	Consult factory																			

IP 00/Chassis	IP 20/Chassis	IP 21/Type 1	With upgrade kit	IP 54/Type 12	IP 55/Type 12	IP 66/NEMA 4X
---------------	---------------	--------------	------------------	---------------	---------------	---------------

Dimensions [mm]

	A1	A2	A3	A4	A5	B1	B2	B3	B4	C1	C2	C3	C4	D1	D2	D3	D4	E1	E2	F1	F2	F3	F4	
H	200	268		390	420	480	650	399	520	680	770	550	660	1209	1589	1046	1327	2000	831	1547	2280	2280	2280	
W	75	90	130	200		242		165	230	308	370	308	370	420		408		600	585	1400	1804	1997	2401	
D	207		205	175	200		260	249	242	310	335		333		380		375		494	498	607	607	607	607
H+			375					475	670			755	950											
W+		90	130					165	255			329	391											

Note: H and W dimensions are with back-plate. H+ and W+ are with IP upgrade kit. D dimensions are without option. A or B for A1, A2 and A3.

FC 300	kW		T6 525 – 600 V								T7 525 – 690 V						
			Amp. HO		Amp. NO		IP 20	IP 21	IP 55	IP 66	Amp. HO		Amp. NO		IP 00	IP 21	IP 54/55
	HO	NO	≤550 V	>550 V	≤550 V	>550 V					550 V	690 V	550 V	690 V			
PK25	0.25																
PK37	0.37																
PK55	0.55																
PK75	0.75				1.8	1.7											
P1K1	1.1				2.6	2.4											
P1K5	1.5				2.9	2.7	A3	A3	A5	A5							
P2K2	2.2				4.1	3.9											
P3K0	3				5.2	4.9											
P3K7	3.7																
P4K0	4.0				6.4	6.1											
P5K5	5.5	7.5			9.5	9	A3	A3	A5	A5							
P7K5	7.5	11			11.5	11											
P11K	11	15	19	18	23	22	B3	B1	B1	B1	14	13	19	18			
P15K	15	18	23	22	28	27					19	18	23	22		B2	B2
P18K	18.5	22	28	27	36	34	B4	B2	B2	B2	23	22	28	27			
P22K	22	30	36	34	43	41					28	27	36	34			
P30K	30	37	43	41	54	52					36	34	43	41			
P37K	37	45	54	52	65	62	C3	C1	C1	C1	43	41	54	52			
P45K	45	55	65	62	87	83					54	52	65	62		C2	C2
P55K	55	75	87	83	105	100					65	62	87	83			
P75K	75	90	105	100	137	131	C4	C2	C2	C2	87	83	105	100			
P90K	90	110									113	108	137	131			
P110	110	132									137	131	162	155	D3	D1	D1
P132	132	160									162	155	201	192			
P160	160	200									201	192	253	242			
P200	200	250									253	242	303	290	D4	D2	D2
P250	250	315									303	290	360	344			
P315	315	355									360	344	418	400			
P355	355	400									395	380	470	450	E2	E1	E1
P400	400	450									429	410	523	500			
P450	450	500															
P500	500	560									523	500	596	570	E2	E1	E1
P560	560	630									596	570	630	630			
P630	630	710									659	630	763	730			
P710	710	800									763	730	899	850		F1/F3	F1/F3
P800	800	1000									889	850	988	945			
P900	900	1000									988	945	1108	1060		F2/F4	F2/F4
P1M0	1000	1200									1108	1060	1317	1260			
P1M2	1200	1400									1317	1260	1479	1415			

# VLT® HVAC Drive



**Perfect**  
**match for:**  
 – Any kind of HVAC application

The VLT® HVAC Drive series is available in a wide power range designed for all HVAC applications. An advanced drive built on HVAC dedication.

The VLT® HVAC Drive is a full-featured, HVAC dedicated drive with built-in intelligence.

The VLT® HVAC Drive has a vast number of functions developed to meet the diverse needs of the HVAC business.

It is the perfect match for pumps, fans and compressors in modern buildings that are fitted with increasingly sophisticated solutions.

### Product range

3 x 200 – 240 V.....	1.1 – 45 kW
3 x 380 – 480 V.....	1.1 – 1000 kW
3 x 525 – 600 V.....	1.1 – 90 kW
3 x 525 – 690 V.....	45 – 1400 kW

*With 110% over load torque*

### Available enclosure ratings

IP 00.....	45 – 630 kW
IP 20.....	1.1 – 90 kW
IP 21 (NEMA 1).....	1.1 – 1400 kW
IP 54 (NEMA 12).....	45 – 1400 kW
IP 55 (NEMA 12).....	1.1 – 90 kW
IP 66 (NEMA 4X indoor).....	1.1 – 90 kW

*Optional coating providing extra protection for aggressive environments.*

Feature	Benefit
<b>All built-in – low investment</b>	
Modular product concept and a wide range of options	Low initial investment – max. flexibility, later upgrade possible
Dedicated HVAC I/O functionality for temperature sensors etc.	External conversion saved
Decentral I/O control via serial communication	Reduced wiring costs, and external controller I/O saved
Wide range of HVAC protocols for BMS controller connectivity	Less extra gateway solutions needed
4 x auto tuned PID's	No external PID controller needed
Smart Logic Controller	Often makes PLC unnecessary
Real Time Clock	Enables daily and weekly settings
Integrated fan, pump and compressor functionality i.e.	Saves external control and conversion equipment
Fire Override Mode, Dry run Detection Constant Torque etc.	Protects equipment and saves energy
Back-channel cooling for frame D, E and F	Prolonged lifetime of electronics
<b>Save energy – less operation cost</b>	
Automatic Energy Optimizer function, advanced version	Saves 5 – 15% energy
Advanced energy monitoring	Overview on energy consumption
Energy saving functions i.e. flow compensation, sleep mode etc.	Saves energy
<b>Unequaled robustness – maximum uptime</b>	
Robust single enclosure	Maintenance-free
Unique cooling concept with no ambient air flow over electronics	Problem-free operation in harsh environments
Max ambient temp. 50° C without derating	No external cooling or oversize necessary
<b>User-friendly – save commissioning and operating cost</b>	
Smart start	Quick and precise start-up
Awarded graphical display, 27 languages	Effective commissioning and operation
USB plug and play connection	Easy to use PC software tools
Global HVAC support organisation	Local service – globally
<b>Built-in DC coils and RFI filters – no EMC concerns</b>	
Integrated DC link harmonic filters	Small power cables. Meets EN 61000-3-12
Integrated EMC filters	Meets EN 55011 Class B, A1 or A2

## Application options

A wide range of integrated HVAC options can be fitted in the drive:

### General purpose I/O option (MCB 101)

3 digital inputs, 2 digital outputs, 1 analogue current output, 2 analogue voltage inputs.

### Relay option (MCB 105)

Adds 3 relay outputs

### Analogue I/O option (MCB 109)

3 Pt1000/Ni1000 inputs, 3 analogue voltage outputs and back-up power for Real-Time Clock.

### External 24 VDC supply (MCB 107)

24 VDC external supply can be connected to supply, control and option cards.

### Sensor input card

Sensor input card for motor protection with 2 or 3 PT100 or PT1000 inputs (MCB114).

### Brake chopper (IGBT) option

Connected to an external brake resistor, the built-in brake chopper limits the load on the intermediate circuit in the case the motor acts as a generator.

## Power options

A wide range of external power options are available for VLT® HVAC Drive in critical networks or applications:

- **Advanced harmonic filters:** For critical demands on harmonic distortion
- **dU/dt filters:** For special demands on motor isolation protection
- **Sine wave filters (LC filters):** For noiseless motor

## HVAC PC software tools

- **MCT 10:** Ideal for commissioning and servicing the drive
- **VLT® Energy Box:** Comprehensive energy analysis tool. Energy consumption with and w/o drive can be calculated (drive payback time). Online function for accessing drives energy log.
- **MCT 31:** Harmonics calculations tool

## Specifications

Mains supply (L1, L2, L3)	
Supply voltage	200–240 V ±10% 380–480 V ±10% 525–600 V ±10% 525–690 V ±10%
Supply frequency	50/60 Hz
Displacement Power Factor (cos φ) near unity	(> 0.98)
Switching on input supply L1, L2, L3	1–2 times/min.
Output data (U, V, W)	
Output voltage	0–100% of supply voltage
Switching on output	Unlimited
Ramp times	1–3600 sec.
Open/Closed loop	0–1000 Hz
Digital inputs	
Programmable digital inputs	6*
Logic	PNP or NPN
Voltage level	0–24 VDC
* 2 can be used as digital outputs	
Pulse inputs	
Programmable pulse inputs	2*
Voltage level	0–24 VDC (PNP positive logic)
Pulse input accuracy	(0.1–110 kHz)
* Utilize some of the digital inputs	
Analogue input	
Analogue inputs	2
Modes	Voltage or current
Voltage level	0 V to +10 V (scaleable)
Current level	0/4 to 20 mA (scaleable)
Analogue output	
Programmable analogue outputs	1
Current range at analogue output	0/4–20 mA
Relay outputs	
Programmable relay outputs	2 (240 VAC, 2 A and 400 VAC, 2 A)
Fieldbus communication	
Standard built-in: FC Protocol N2 Metasys FLN Apogee Modbus RTU BACnet embedded	Optional: LonWorks (MCA 108) BACnet (MCA 109) DeviceNet (MCA 104) Profibus (MCA 101)

## High power options

- IEC Emergency stop with Safety Relay
- Safety Stop with Safety Relay
- RFI Filters
- NAMUR terminals
- RCD
- IRM
- Mains shielding
- Regen terminals

Please see the VLT® High Power Drive Selection Guide for the complete range of options.

## The Danfoss EC+ concept...

... enables the use of PM motors in IEC-standard sizes with Danfoss VLT® frequency converters. After entering the relevant motor data, you benefit from the high engine efficiency at EC tech-

nology level in all applications. Necessary control method has been embedded in dedicated VLT® series drives.

## Benefits of the EC + concept:

- Free choice of motor technology: PM or asynchronous with same frequency converter
- Operation and installation of the VLT® drive remain the same
- Vendor-independent election of all components
- Best system efficiency by combining efficiency-optimized components
- Retrofit of existing plants
- Support a broad range of standard and PM motors



Current and power ratings

FC 102	kW	T2 200 – 240 V				T4 380 – 480 V						T6 525 – 600 V				T7 525 – 690 V										
		Amp.	IP 20	IP 21	IP 55	IP 66	Amp.		IP 00	IP 20	IP 21	IP 54	IP 55	IP 66	Amp.		IP 20	IP 21	IP 55	IP 66	Amp.		IP 00	IP 21	IP 54/55	
							≤440 V	>440 V							≤550 V	>550 V					550 V	690 V				
P1K1	1.1	6.6					3	2.7						2.6	2.4											
P1K5	1.5	7.5	A2	A2	A4/A5	A4/A5	4.1	3.4		A2	A2			2.9	2.7	A3	A3	A5	A5							
P2K2	2.2	10.6					5.6	4.8						4.1	3.9											
P3K0	3	12.5					7.2	6.3						5.2	4.9											
P3K7	3.7	16.7	A3	A3	A5	A5																				
P4K0	4.0						10	8.2		A2	A2			6.4	6.1											
P5K5	5.5	24.2					13	11		A3	A3			9.5	9	A3	A3	A5	A5							
P7K5	7.5	30.8	B3	B1	B1	B1	16	14.5						11.5	11											
P11K	11	46.2					24	21						19	18											
P15K	15	59.4					32	27		B3	B1			23	22	B3	B1	B1	B1							
P18K	18	74.8	B4				37.5	34						28	27											
P22K	22	88					44	40						36	34											
P30K	30	115	C3	C1	C1	C1	61	52		B4	B2			43	41	B4	B2	B2	B2							
P37K	37	143					73	65						54	52											
P45K	45	170	C4	C2	C2	C2	90	80						65	62	C3	C1	C1	C1			56	54			
P55K	55						106	105						87	83							76	73			
P75K	75						147	130		C4	C2			105	100	C4	C2	C2	C2			90	86			
P90K	90						177	160						137	131							113	108	D3	D1	D1
P110	110						212	190		D3		D1	D1									137	131			
P132	132						260	240														162	155			
P160	160						315	302														201	192			
P200	200						395	361		D4		D2	D2									253	242			
P250	250						480	443														303	290	D4	D2	D2
P315	315						600	540														360	344			
P355	355						658	590																		
P400	400						745	678		E2		E1	E1									418	400	D4	D2	D2
P450	450						800	730														470	450			
P500	500						880	780														523	500	E2	E1	E1
P560	560						990	890				F1/F3	F1/F3									596	570			
P630	630						1120	1050														630	630			
P710	710						1260	1160														763	730			
P800	800						1460	1380				F2/F4										889	850		F1/F3	F1/F3
P900	900																					988	945			
P1M0	1000						1720	1530				F2/F4										1108	1060		F2/F4	F2/F4
P1M2	1200																					1317	1260		F2/F4	F2/F4
P1M4	1400																					1479	1415			

IP 00/Chassis	IP 20/Chassis	IP 21/Type 1	With upgrade kit	IP 54/Type 12	IP 55/Type 12	IP 66/NEMA 4X
---------------	---------------	--------------	------------------	---------------	---------------	---------------

Dimensions [mm]

	A2	A3	A4	A5	B1	B2	B3	B4	C1	C2	C3	C4	D1	D2	D3	D4	E1	E2	F1	F2	F3	F4
H	268	390	420	480	650	399	520	680	770	550	660	1209	1589	1046	1327	2000	831	1547	2280	2280	2280	2280
W	90	130	200	242	165	230	308	370	308	370	308	370	420	408	408	600	585	1400	1804	1997	2401	2401
D	205	175	200	260	249	242	310	335	333	380	375	494	498	607	607	607	607	607	607	607	607	607
H+	375				475	670			755	950												
W+	90	130			165	255			329	391												

Note: H and W dimensions are with back-plate. H+ and W+ are with IP upgrade kit. D dimensions are without option. A or B for A2 and A3.

# VLT® AQUA Drive



## Perfect

match for:

- Water supply
- Wastewater treatment
- District heating
- Irrigation

Danfoss VLT Drives' unequalled experience was used to make VLT® AQUA Drive the perfect match for AC motor driven applications in modern water and wastewater systems – also for retrofitting.

Danfoss VLT® AQUA Drive is dedicated to water and wastewater applications. With a wide range of powerful standard and optional features, VLT® AQUA Drive provides the lowest overall cost of ownership for water and wastewater applications.

### Power range

1 x 200 – 240 V AC .....	1.1 – 22 kW
1 x 380 – 480 V AC .....	7.5 – 37 kW
3 x 200 – 240 V AC .....	0.25 – 45 kW
3 x 380 – 480 V AC .....	0.37 – 1000 kW
3 x 525 – 600 V AC .....	0.75 – 90 kW
3 x 525 – 690 V AC .....	11 – 1400 kW

### Application options

A wide range of integrated options can be fitted in the drive:

#### General purpose I/O option (MCB 101)

3 digital inputs, 2 digital outputs,  
1 analogue current output,  
2 analogue voltage inputs.

*Continued on the next page!*

Feature	Benefit
<b>Dedicated features</b>	
Dry run detection	Protects the pump
Flow compensation function	Saves energy
2 step ramps (initial ramp)	Protects deep well pumps
Check valve ramp	Protects against water hammer and saves installed cost on soft close valves
Pipe fill mode	Eliminates water hammering
Built-in motor alternation feature	Duty-stand by operation, cost reduction
Sleep Mode	Saves energy
No/low flow detection	Protects the pump
End of pump-curve detection	Protects the pump, leakage detection
Pump cascade controller	Lower equipment cost
Back-channel cooling for frame D, E and F	Prolonged lifetime of electronics
<b>Energy saving</b>	
VLT® efficiency (98%)	Saves energy
Automatic Energy Optimisation (AEO)	Saves 3 – 8% energy
Sleep Mode function	Saves energy
Master/follower control	Saves up to 15% energy
Auto Tuning of Staging Speeds	Smoothens the staging and saves energy
Flow Compensation	Saves Energy by self-adjusting the set-point
<b>Reliable</b>	
IP 20 – IP 66 enclosures	Outdoor mounting
All power sizes available in IP 54/55 enclosures	Broad usability in standard factory supplied enclosure
Password protection	Reliable operation
Mains disconnect switch	No need for external switch
Optional, built-in RFI suppression	No need for external modules
Built-in Smart Logic Controller	Often makes PLC omissible
One Wire safe stop	Safe operation/less wiring
Max. ambient temperature up to 50° C without derating	Reduced need for cooling
<b>User-friendly</b>	
Award winning control panel (LCP)	Effective commissioning and operation
One drive type for the full power range	Less learning required
Intuitive user interface	Time saved
Integrated Real Time Clock	Lower equipment cost
Modular design	Enables fast installation of options
Auto tuning of PI-controllers	Time saved
Payback time indication	Less worries

## Application options

### Cascade Controller (MCO 101, 102)

Upgrade the built-in cascade controller to operate more pumps with a higher energy efficiency, using master/follower pump control. Running the pumps in use at the same speed and optimising staging speeds automatically during operation. At the same time runtime of all pumps is balanced to distribute wear and tear evenly.

### Relay & Analogue I/O option (MCB 105, 109)

Upgrade to advanced performance and control using the additional in/outputs.

### Sensor Input Option (MCB 114)

Monitors the PT100/PT1000 installed in the motor winding and bearing temperatures and protects them from overheating according to customised limits.

### PTC Thermistor Card (MCB 112)

The MCB 112 is connected to safe stop and protects the motor from overheating. It is approved for controlling a certified Ex proof motor in a potentially explosive atmosphere (ATEX) in zones 1 + 2 (gas) zones 21 + 22 (dust).

**Profibus (MCA 101),  
DeviceNet (MCA 104)  
PTC Thermistor Card (MCB 112)  
Profinet SRT (MCA 120)  
EtherNet IP (MCA 121) and  
Modbus TCP (MCA 122)  
Fieldbus options.**

**24 V DC supply option (MCB 107)**  
Back-up option to keep the control system alive during mains loss.

### Coated PCB available

For harsh environments, according to levels in IEC61721-3-3, standard 3C2, optional 3C3.

## High power options

Please see the VLT® High Power Drive Selection Guide for the complete range of options.

## Specifications

Mains supply (L1, L2, L3)	
Supply voltage	200 – 240 V ±10%, 380 – 480 V ±10%, 525 – 600 V ±10%, 525 – 690 V ±10%
Supply frequency	50/60 Hz
Displacement Power Factor (cos φ) near unity	(> 0.98)
True power factor (λ)	≥ 0.9
Switching on input supply L1, L2, L3	1 – 2 times/min.

Output data (U, V, W)	
Output voltage	0 – 100% of supply
Switching on output	Unlimited
Ramp times	0.1 – 3600 sec.
Output frequency (dependent on power size)	1000 Hz

*Note: VLT® AQUA Drive can provide 110% current for 1 minute. Higher overload rating is achieved by oversizing the drive.*

Digital inputs	
Programmable digital inputs	6*
Logic	PNP or NPN
Voltage level	0 – 24 VDC

*\* Two of the inputs can be used as digital outputs.*

Analogue inputs	
Number of analogue inputs	2
Modes	Voltage or current
Voltage level	-10 to +10 V (scaleable)
Current level	0/4 to 20 mA (scaleable)

Pulse inputs	
Programmable pulse inputs	2
Voltage level	0 – 24 VDC (PNP positive logic)
Pulse input accuracy	(0.1 – 110 kHz)

*\* Two of the digital inputs can be used for pulse inputs.*

Analogue output	
Programmable analogue outputs	1
Current range at analogue output	0/4 – 20 mA

Relay outputs	
Programmable relay outputs	2 (240 VAC, 2 A and 400 VAC, 2 A)

Fieldbus Communication	
FC Protocol and Modbus RTU built-in (Optional: Modbus TCP, Profibus, DeviceNet, Ethernet IP)	

Ambient temperature	
Up to 55° C (50° C without derating)	

## Power options

We offer a wide range of external power options for use together with our drive in critical networks or applications:

- **VLT® Low Harmonic Drive:** Optimum reduction of harmonic distortion with built-in active filter.
- **VLT® Advanced Harmonic Filter:** For applications where reducing harmonic distortion is critical.
- **dU/dt filter:** For providing motor isolation protection.
- **Sine wave filter (LC filter):** For noiseless motor.

## AQUA PC software tools

- **MCT 10:** Ideal for commissioning and servicing the drive including guided programming of cascade controller, real time clock, smart logic controller and preventive maintenance.
- **VLT® Energy Box:** Comprehensive energy analysis tool. Energy consumption with and w/o drive can be calculated (drive payback time). Online function for accessing drives energy log.
- **MCT 31:** Harmonics calculations tool.



# VLT® 2800 Series



## Perfect

### match for:

- Conveyors, centrifuges, dosing pumps, compressors
- Special applications like cutting machines with constant speed, and packaging machines with a need for high precision

The VLT® 2800 series has been developed for the low power market. The drive is extremely compact and prepared for side-by-side mounting. The concept is modular with a power module and a control module.

The VLT® 2800 series is designed for stable operation in industrial environments.

### Power range

1/3 x 200 – 240 V.....0.37 – 3.7 kW  
3 x 380 – 480 V.....0.55 – 18.5 kW

*With 160% overload torque (normal overload)*

Feature	Benefit
Automatic Motor Tuning	- Ensure optimal match between drive and motor - Increasing performance
PID-controller	- Optimum process control
Interrupt start/stop	- High repeatability of positional accuracy
Dry run detection	- No need for specific detection equipment
Fieldbus communication	- Allows for control and surveillance of the drives from a PC or a PLC - Profibus and DeviceNet are available
Reliable	Maximum uptime
Built-in RFI filter	- Compliance with the EMC standard EN 55011 1A
Enhanced sleep mode	- Excellent control for shutting down the pump at low flow
Max. ambient temperature 45° C without derating	- No external cooling or oversizing necessary
User-friendly	Saves commissioning and operating cost
Quick Menu	- Easy to use
Pipe Fill mode	- Prevents water hammering
Fieldbus communication	- Allows for control and surveillance of the drives from a PC or a PLC - Profibus and DeviceNet are available

## PC software tools

- **MCT 10:**  
Ideal for commissioning and servicing the drive.
- **MCT 31:**  
Harmonics calculations tool.

## RFI filter

The RFI filter ensures that the frequency converter will not disrupt other electrical components that are connected to the mains and might cause operating disruption.

By fitting an RFI 1B filter module between the mains supply and the VLT® 2800, the solution complies with the EMC norm EN 55011-1B.

## Specifications

Mains supply (L1, L2, L3)	
Supply voltage	200-240 V ±10%, 380-480 V ±10%
Supply frequency	50/60 Hz
Displacement Power Factor (cos φ) near unity	(> 0.98)
Switching on input supply L1, L2, L3	1-2 times/min.
Output data (U, V, W)	
Output voltage	0-100% of supply voltage
Switching on output	Unlimited
Ramp times	1-3600 sec.
Closed loop	0-132 Hz
Digital inputs	
For start/stop, reset, thermistor, etc.	5
Logic	PNP or NPN
Voltage level	0-24 VDC
Analogue input	
No. of analogue inputs	2
Voltage level	-10 to +10 V (scaleable)
Current level	0/4 to 20 mA (scaleable)
Pulse inputs	
No. of pulse inputs	2
Voltage level	0-24 V DC (PNP positive logic)
Pulse input accuracy	(0.1-110 kHz)
Digital output	
No. of digital outputs	1
Analogue output	
Programmable analogue outputs	1
Current range	0/4-20 mA
Relay outputs	
No. of relay outputs	1
Fieldbus communication	
RS485	
Ambient temperature	
50°C	

Mains	Type	Power		Input current	
		P <sub>N,M</sub> [kW]	I <sub>INV</sub> [A]	I <sub>L,N</sub> [A]	
1 x 220-240 V	2803	0.37	2.2	5.9	
	2805	0.55	3.2	8.3	
	2807	0.75	4.2	10.6	
	2811	1.1	6.0	14.5	
	2815	1.5	6.8	15.2	
	2822*	2.2	9.6	22.0	
	2840*	3.7	16.0	31.0	
3 x 200-240 V	2803	0.37	2.2	2.9	
	2805	0.55	3.2	4.0	
	2807	0.75	4.2	5.1	
	2811	1.1	6.0	7.0	
	2815	1.5	6.8	7.6	
	2822	2.2	9.6	8.8	
	2840	3.7	16.0	14.7	
3 x 380-480 V	2805	0.55	1.7	1.6	
	2807	0.75	2.1	1.9	
	2811	1.1	3.0	2.6	
	2815	1.5	3.7	3.2	
	2822	2.2	5.2	4.7	
	2830	3.0	7.0	6.1	
	2840	4.0	9.1	8.1	
	2855	5.5	12	10.6	
	2875	7.5	16	14.9	
	2880	11.0	24	24.0	
2881	15.0	32	32.0		
2882	18.5	37.5	37.5		

\* Not available with RFI filter

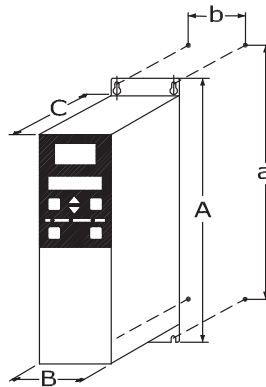

## Cabinet sizes [mm]

Height				
	A	B	C	D
A	200	267.5	267.5	505
a	191	257	257	490
Width				
	B			
B	75	90	140	200
b	60	70	120	120
Depth				
	C			
C	168	168	168	244



# VLT® Micro Drive



## Perfect

match for:

- Industrial automation
- HVAC applications
- OEM

The VLT® Micro Drive is a general purpose drive that can control AC motors up to 22 kW. It's a small drive with maximum strength and reliability.

VLT® Micro Drive is a full member of the VLT® family sharing the overall quality of design, reliability and user-friendliness.

Due to high quality components and genuine VLT® solutions, VLT® Micro Drive is extremely reliable.

### RoHS compliant

The VLT® Micro Drive is manufactured with respect for the environment, and it complies with the RoHS Directive.

### Power range

1 phase 200–240 V AC ..... 0.18–2.2 kW  
 3 phase 200–240 V AC ..... 0.25–3.7 kW  
 3 phase 380–480 V AC ..... 0.37–22 kW

Feature	Benefit
<b>User friendly</b>	
Minimum commissioning	Saves time
Mount – connect – go!	Minimum effort – minimum time
Copy settings via local control panel	Easy programming of multiple drives
Intuitive parameter structure	Minimal manual reading
Complies with VLT® software	Saves commissioning time
Self-protecting features	Lean operation
Process PI-controller	No need for external controller
Automatic Motor Tuning	Ensure optimal match between drive and motor
150% motor torque up to 1 minute	Plenty of brake-away and acceleration torque
Flying start (catch a spinning motor)	Doesn't trip when started on a spinning (freewheeling) motor
Electronic Thermal Relay (ETR)	Replaces external motor protection
Smart Logic Controller	Often makes PLC unnecessary
Built-in RFI filter	Saves cost and space
<b>Energy saving</b>	
Energy efficiency 98%	Minimises heat loss
Automatic Energy Optimisation (AEO)	Saves 5-15% energy in HVAC applications
<b>Reliable</b>	
Earth fault protection	Protects the drive
Over temperature protection	Protects the motor and drive
Short circuit protection	Protects the drive
Optimum heat dissipation	Longer lifetime
Unique cooling concept with no forced air flow over electronics	Problem-free operation in harsh environments
High quality electronics	Low lifetime cost
High quality capacitors	Tolerates uneven mains supply
All drives full load tested from factory	High reliability
Dust resistant	Increased lifetime
RoHS compliant	Protects the environment
Designed for WEEE	Protects the environment

## Coated PCB standard

For harsh environments.

## Power options

Danfoss VLT Drives offers a range of external power options for use together with our drives in critical networks or applications:

- **VLT® Advanced Harmonic Filter:**  
For applications where reducing harmonic distortion is critical.

## PC software tools

- **MCT 10:**  
Ideal for commissioning and servicing the drive including guided programming of cascade controller, real time clock, smart logic controller and preventive maintenance.
- **VLT® Energy Box:**  
Comprehensive energy analysis tool, shows the drive payback time.
- **MCT 31:**  
Harmonics calculations tool.



## Cabinet sizes

(mounting flange incl.)

[mm]	M1	M2	M3	M4	M5
Height	150	176	239	292	335
Width	70	75	90	125	165
Depth	148	168	194	241	248

+ 6 mm with potentiometer

## Specifications

Mains supply (L1, L2, L3)	
Supply voltage	1 x 200–240 V ± 10%, 3 x 200–240 V ± 10% 3 x 380–480 V ± 10%
Supply frequency	50/60 Hz
Displacement Power Factor (cos φ) near unity	(> 0.98)
Switching on input supply L1, L2, L3	1–2 times/min.
Output data (U, V, W)	
Output voltage	0–100% of supply voltage
Output frequency	0–200 Hz (VVC+ mode), 0–400 Hz (U/f mode)
Switching on output	Unlimited
Ramp times	0.05–3600 sec
Digital inputs	
Programmable digital inputs	5
Logic	PNP or NPN
Voltage level	0–24 VDC
Pulse inputs	
Programmable pulse inputs	1*
Voltage level	0–24 V DC (PNP positive logic)
Pulse input frequency	20–5000 Hz

\* One of the digital inputs can be used for pulse inputs.

Analogue input	
Analogue inputs	2
Modes	1 current/1 voltage or current
Voltage level	0–10 V (scaleable)
Current level	0/4 to 20 mA (scaleable)
Analogue output	
Programmable analog outputs	1
Current range at analog output	0/4–20 mA
Relay outputs	
Programmable relay outputs	1 (240 VAC, 2 A)
Approvals	
CE, C-tick, UL	
Fieldbus communication	
FC Protocol, Modbus RTU	

## Ordering numbers

Power [kW]	200 V			400 V	
	Current [I-nom.]	1 ph.	3 ph.	Current [I-nom.]	3 ph.
0.18	1.2	132F 0001			
0.25	1.5		132F 0008		
0.37	2.2	132F 0002	132F 0009	1.2	132F 0017
0.75	4.2	132F 0003	132F 0010	2.2	132F 0018
1.5	6.8	132F 0005	132F 0012	3.7	132F 0020
2.2	9.6	132F 0007	132F 0014	5.3	132F 0022
3.0				7.2	132F 0024
3.7	15.2		132F 0016		
4.0				9.0	132F 0026
5.5				12.0	132F 0028
7.5				15.5	132F 0030
11.0				23.0	132F 0058
15.0				31.0	132F 0059
18.5				37.0	132F 0060
22.0				43.0	132F 0061

Micro drives from 1.5 kW and up have built in brake chopper

VLT® Control panel LCP 11 ..... Without potentiometer: 132B0100  
 VLT® Control panel LCP 12 ..... With potentiometer: 132B0101

# VLT® Decentral Drive FCD 302



## Perfect

match for:

- Conveyor applications
- Installation in wash-down areas
- Widely distributed applications, with large number of drives

The VLT® Decentral Drive FCD 302 is the new generation of the VLT® Decentral FCD 300, based on the VLT® AutomationDrive FC 302 platform. It combines the key features of both products in a completely re-designed enclosure, made for best fit on direct machine mounting.

Simplicity and robustness have been taken into consideration during the design of the new VLT® Decentral Drive FCD 302, resulting in a real user-friendly product, with high performance and the highest protection degree.

Decentral drives are meant for de-located mounting, where the need for space-consuming control cabinets is eliminated. With the drives placed near – or directly on – the motor, there is no need for long screened motor cables.

### One-box concept

All options are built as part of the unit, reducing the number of boxes to be mounted, connections and terminations in the installation. Consequently labor costs in mounting hours and risk of failures are dramatically reduced.

### Power range

0.37 – 3 kW, 3 x 380 – 480 V

Feature	Benefit
<b>Reliable</b>	<b>Maximum uptime</b>
Special painting treatment and smooth surface	Easy cleaning; no dirt trap
Pluggable twin-part design (installation box and electronic part)	Easy and fast service
Integrated lockable service switch available	Local disconnection possible
<b>User-friendly</b>	<b>Saves commissioning and operating cost</b>
Adapts to any brand of motor and geared motor, induction as well as permanent magnet motors	Easy and flexible installation
Integrated power and fieldbus looping terminals	Cable savings
Visible LEDs	Quick status check
Set-up and controlled through pluggable control panel, fieldbus communication and MCT10 PC software	Easy commissioning
Awarded control panel with on-board manual	Easy operation
Screwless spring-loaded terminals	Easy and fast connection
Integrated USB port	Direct connection to PC
<b>Intelligent</b>	<b>Built-in feature</b>
Smart Logic Control	Reduces need for PLC capacity
Safe Stop, STO: Safe Torque Off	Reduces the need for extra components
Intelligent warning systems	Warning before controlled stop

### Enclosure

- IP 66 standard black
  - IP 66 standard white
  - IP 69K hygienic white
- (all enclosures are rated as Type 4X)

## Integrated 24 V supply

24 V DC control supply is provided by the drive. Separate supply terminals have been made for remote I/Os distribution.

## Power looping

The new FCD 302 facilitates internal power looping. Terminals for 6 mm<sup>2</sup> power cable inside the enclosure allows connection of multiple units in the same branch.

## Ethernet switch

Two RJ-45 ports are available in the drive for easy daisy chaining of Ethernet communication.

## Fieldbus options

- PROFIBUS DP
- PROFINET
- Ethernet/IP

## Application options

- Encoder
- Resolver

## Hardware options

- Mounting brackets
- Service switch
- Internal circuit breaker
- M12 sensor plugs
- 24 V DC input for control supply
- Brake chopper
- Electromechanical brake control and supply

## Dimensions

### Small frame size

(0.37 – 2.2 kW/0.5 – 3.0 HP)

### Large frame size

(0.37 – 3 kW/0.5 – 4.0 HP)

## Specifications

Mains supply (L1, L2, L3)	
Supply voltage	380 – 480 V ±10%
Supply frequency	50/60 Hz
True Power Factor (λ)	0.92 nominal at rated load
Displacement Power Factor (cos φ)	(>0.98)
Switching on input supply	2 times/min.
Output data (U, V, W)	
Output voltage	0 – 100% of supply
Output frequency	0 – 1000 Hz 0 – 300 Hz (Flux mode)
Switching on output	Unlimited
Ramp times	0.01 – 3600 sec.
Digital inputs	
Programmable digital inputs	4 (6)
Logic	PNP or NPN
Voltage level	0 – 24 V DC
<i>Note: One/two digital inputs can be programmed as digital output</i>	
Analogue inputs	
Number of analogue inputs	2
Modes	Voltage or current
Voltage level	-10 to +10 V (scaleable)
Current level	0/4 – 20 mA (scaleable)
Pulse/encoder inputs	
Programmable pulse/encoder inputs	2
Voltage level	0 – 24 V DC (PNP positive logic)
Digital output	
Programmable digital/pulse outputs	2
Voltage level at digital/frequency output	0 – 24 V
Analogue output	
Programmable analogue outputs	1
Current range	0/4 – 20 mA
Relay outputs	
Programmable relay outputs	2
Integrated 24 V supply	
Max. load	600 mA

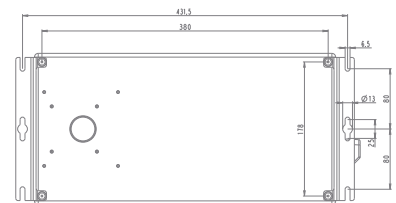
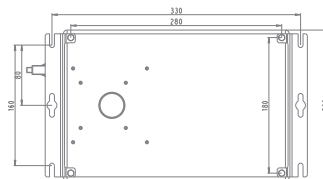
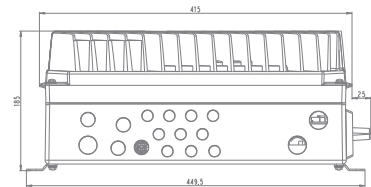
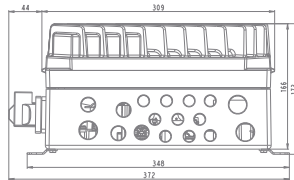
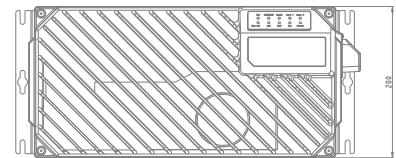
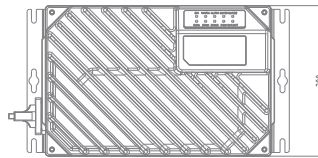

All measurements are in mm

# VLT® Decentral FCD 300



## Perfect

match for:

- Material handling in Food & Beverage and Industry
- Installations in wash-down areas
- Widely distributed applications

The VLT® Decentral FCD 300 is a complete frequency converter designed for decentral mounting. It can be mounted on the machine or wall close to the motor, or directly on the motor.

The VLT® Decentral FCD 300 comes in very robust enclosure, with a special painting treatment to withstand harsh environments and typical cleaning agents used in wash-down areas. Its design offers a smooth cleaning-friendly surface.

The decentral design reduces the need for central control panels and eliminates the need for space-consuming motor control cabinets. The need for long screened motor cables is significantly reduced.

Feature	Benefit
<b>Reliable</b>	<b>Maximum uptime</b>
Special surface treatment as protection against aggressive environments	Easy cleaning; no dirt trap
Twin part design (installation box and electronic part)	Easy and fast service
Integrated lockable service switch available	Local disconnection possible
Full protection is offered	Protects the motor and drive
<b>User-friendly</b>	<b>Saves commissioning and operating cost</b>
Adapts to any brand of motor and geared motor	Easy and flexible installation
Designed for power and fieldbus looping	Cable savings
Visible LEDs	Quick status check
Set-up and controlled through a remote control panel or fieldbus communication and dedicated MCT 10 set-up software	Easy commissioning

### Power range

0.37 – 3.3 kW, 3 x 380 – 480 V

### Enclosure

IP 66/Type 4X (indoor)

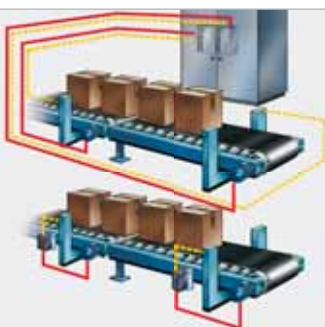

Central Vs. Decentral concept



Robust cleaning-friendly surface



Hot pluggable LCP

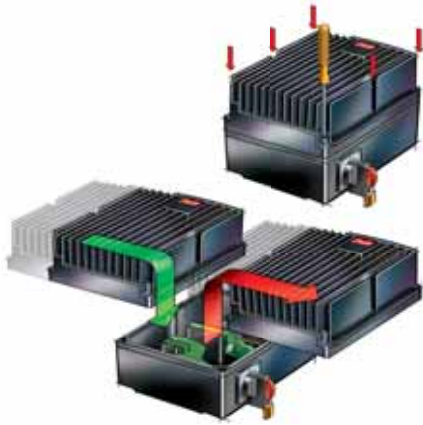

## Plug-and-drive

The bottom section contains maintenance-free Cage Clamp connectors and looping facilities for power and fieldbus cables. Once installed, commissioning and upgrading can be performed in no time by plugging in another control lid.

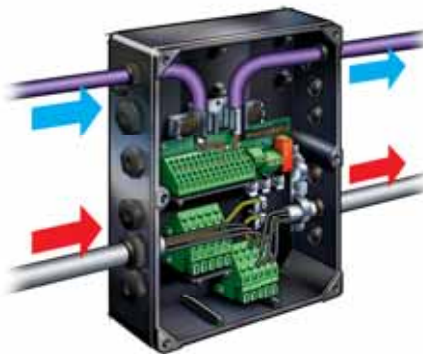

## Flexible installation

The FCD 300 series facilitates internal power line and fieldbus looping. Terminals for 4 mm<sup>2</sup> power cables inside the enclosure allows connection of up to 10+ units.

## Available options

- Service switch
- Connector for control panel
- M12 connectors for external sensors
- Han 10E motor connector
- Brake chopper and resistor
- 24 V external back up of control and communication
- External electromechanical brake control and supply

## Specifications

Mains supply (L1, L2, L3)	
Supply voltage	3 x 380/400/415/440/480 V ± 10%
Supply frequency	50/60 Hz
Max. imbalance on supply voltage	±2.0% of rated supply voltage
Switching on input supply	2 times/min.
Power Factor (cos φ)	0.9 / 1.0 at rated load
Output data (U, V, W)	
Output voltage	0–100% of supply
Overload torque	160% for 60 sec.
Switching on output	Unlimited
Ramp times	0.02 - 3600 sec.
Output frequency	0.2 - 132 Hz, 1 - 1000 Hz
Digital inputs	
Programmable digital inputs	5
Voltage level	0–24 V DC (PNP positive logic)
Analog inputs	
Analog inputs	2 (1 voltage, 1 current)
Voltage level/Current level	0– ±10 V DC / 0/4–20 mA (scaleables)
Pulse inputs	
Programmable pulse inputs	2 (24 V DC)
Max. frequency	110 kHz (push-pull) / 5 kHz (open collector)
Analog output	
Programmable analog output	1
Current range	0/4–20 mA
Digital output	
Programmable digital/frequency output	1
Voltage/frequency level	24 V DC/10 kHz (max.)
Relay output	
Programmable relay output	1
Max. terminal load	250 V AC, 2 A, 500 VA
Fieldbus communication	
FC Protocol, Modbus RTU, Metasys N2	Built-in
Profibus DP, DeviceNet, AS-interface	Optional (integrated)
Externals	
Vibration test	1.0 g (IEC 60068)
Max. relative humidity	95 % (IEC 60068-2-3)
Ambient temperature	Max. 40°C (24 hour average max. 35°C)
Min. ambient temperature in full operation	0°C
Min. ambient temperature at reduced performance	-10°C
Approvals	CE, UL, C-tick, ATEX*

\* Contact Danfoss for details

## Technical data

VLT® Decentral FCD		303	305	307	311	315	322	330	335*
Output current (3 x 380 – 480 V)	I <sub>INV (60s)</sub> [A]	1.4	1.8	2.2	3.0	3.7	5.2	7.0	7.6
	I <sub>MAX (60s)</sub> [A]	2.2	2.9	3.5	4.8	5.9	8.3	11.2	11.4
Output power (400 V)	S <sub>INV</sub> [KVA]	1.0	1.2	1.5	2.0	2.6	3.6	4.8	5.3
	P <sub>M,N</sub> [kW]	0.37	0.55	0.75	1.1	1.5	2.2	3.0	3.3
Typical shaft output	P <sub>M,N</sub> [HP]	0.5	0.75	1.0	1.5	2.0	3.0	4.0	5.0
	Mechanical dimensions H x W x D (mm)	Motor mounting	244 x 192 x 142					300 x 258 x 151	
	Stand alone	300 x 192 x 145					367 x 258 x 154		

\* t<sub>amb</sub> max. 35°C

# VLT® DriveMotor FCM 300



## Perfect

### match for:

- Air Handling Unit fan wheels
- Pumps
- Simple conveyors



The VLT® FCM 300 Series is an integrated drive-motor solution which combines a VLT® frequency converter and a high standard quality motor in a single product.

The frequency converter is attached in place of the motor terminal box and it is no higher than the standard terminal box nor wider or longer than the motor.

Incorporated to a high standard quality motor, the VLT® DriveMotor FCM 300 is also available in a multitude of variants, individualised to meet customer requirements.

### On the motor

The VLT® electronic motor control together with the motor totally eliminates motor cables and thereby minimises EMC problems. Heat from the drive is dissipated together with the motor heat.

### Power range

0.55 – 7.5 kW, 3 x 380 – 480 V

Feature	Benefit
<b>Reliable</b>	<b>Maximum uptime</b>
Robust enclosure	Withstands harsh environments
No power cable length limitation	Increased flexibility
Thermal protection	Total motor-inverter protection
Straightforward EMC compliance	No problem with electromagnetic interferences
<b>User-friendly</b>	<b>Saves commissioning and operating cost</b>
Motor and drive perfectly matched to each other	Saves commissioning time
No panel space required – the DriveMotor is placed on the machine	Saves space
Flexible mounting – foot/flange/face/foot-flange/foot-face	Meets customer requirements
Retrofit without mechanical changes	Easy service
Set-up and controlled through a remote control panel or fieldbus communication and dedicated MCT 10 set-up software	Easy commissioning

### Enclosure

IP 55 (standard)  
IP 65/IP 66 (optional)

### Motor type

2-pole  
4-pole

### Mounting versions

B03 foot  
B05 flange  
B35 foot + flange  
B14 face  
B34 foot + face



## Control panel

A Local Control Panel is available for operating, setup and diagnostics. The LCP can be handheld or mounted in a panel front (IP65).

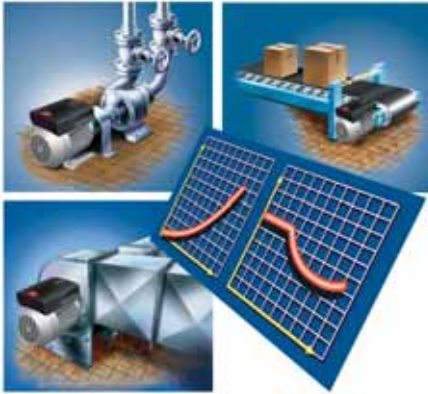

## Sleep Mode

In Sleep Mode the motor will stop in a no load situation. When the load returns, the frequency converter will restart the motor.

Also available:

### Forced ventilation

For constant operation at low speed without torque reduction.

### Motor drain holes

For applications where formation of condensate water might occur.

## Sensorless Pump Control – OEM version

Offers precise pressure (head) control without using a pressure transmitter.

## Specifications

Mains supply (L1, L2, L3)	
Supply voltage	3 x 380/400/415/440/460/480V ± 10%
Supply frequency	50/60 Hz
Power factor (cos φ)	Max. 0.9/1.0 at rated load
Max. imbalance of supply voltage	± 2% of rated supply voltage
Switching on supply input	Once every 2 minutes
Control Characteristics (frequency converter)	
Frequency range	0 – 132 Hz
Overload torque	160% for 60 sec.
Resolution on output frequency	0.1%
System response time	30 msec. ± 10 msec.
Speed accuracy	± 15 RPM (open loop, CT mode, 4-pole motor 150 – 1500 RPM)
Digital inputs	
Programmable digital inputs	4
Voltage level	0 – 24 V DC (PNP positive logic)
Analog inputs	
Analog inputs	2 (1 voltage, 1 current)
Voltage/current level	0 – 10 V DC / 0/4 – 20 mA (scaleables)
Pulse input	
Programmable pulse input	1 (24 V DC)
Max. frequency	70 kHz (push-pull) / 8 kHz (open collector)
Analog/digital output	
Programmable analog/digital output	1
Current/voltage range	0/4 – 20 mA / 24 V DC
Relay output	
Programmable relay output	1
Max. terminal load	250 V AC, 2 A, 500 VA
Fieldbus communication	
FC Protocol, Modbus RTU	Built-in
Profibus DP	Optional (integrated)
Externals	
Vibration test	1.0 g (IEC 60068)
Max. relative humidity	95% (IEC 60068-2-3)
Ambient temperature	Max. 40° C (24 hour average max. 35° C)
Min. ambient temperature in full operation	0° C
Min. ambient temperature at reduced performance	-10° C

## Technical data

FCM	305	307	311	315	322	330	340	355	375
<b>Motor output</b>									
[HP]	0.75	1.0	1.5	2.0	3.0	4.0	5.0	7.5	10.0
[kW]	0.55	0.75	1.1	1.5	2.2	3.0	4.0	5.5	7.5
<b>Motor torque</b>									
2-pole [Nm] 1)	1.8	2.4	3.5	4.8	7.0	9.5	12.6	17.5	24.0
4-pole [Nm] 2)	3.5	4.8	7.0	9.6	14.0	19.1	25.4	35.0	48.0
<b>Frame size</b>									
[mm]	80	80	90	90	100	100	112	132	132
<b>Input current [A] 380 V</b>									
2-pole	1.5	1.8	2.3	3.4	4.5	5.0	8.0	12.0	15.0
4-pole	1.4	1.7	2.5	3.3	4.7	6.4	8.0	11.0	15.5
<b>Input current [A] 480 V</b>									
2-pole	1.2	1.4	1.8	2.7	3.6	4.0	6.3	9.5	11.9
4-pole	1.1	1.3	2.0	2.6	3.7	5.1	6.3	8.7	12.3

1) at 400 V, 3000 RPM, 2) at 400 V, 1500 RPM

# VLT® OneGearDrive



## Perfect

match for:

- Dry and wet areas
- Clean room production areas

The compact design of the VLT® OneGearDrive makes it predestined for use in transport and conveying systems as well as machines and equipment. The drive has been designed especially for use in the food and beverage industry although this new generation of transmission product offers significant benefits in all conveyor drive applications.

Compared to traditional systems the VLT® OneGearDrive covers all applications with one drive size and only a low number of variants, reducing spare part inventory and easing engineering thanks to uniform mechanical dimensions. The high-efficiency bevel gearing with permanent-magnet three-phase synchronous motor offers high energy efficiency – up to 25% power savings compared to conventional systems.

The VLT® OneGearDrive comes in two versions, the OneGearDrive Standard™ for use in dry and wet production areas and the OneGearDrive Hygienic™ for use in wet areas, areas with high cleaning intensity and aseptic and clean room production areas.

In both versions the complete smooth, easy to clean surface without cooling fins prevents pockets of dirt from forming and allows cleansing agents to drain off freely. The fanless motor avoids the risk of air-borne germs and dirt particles being drawn in and then expelled back into the surrounding air.

Feature	Benefit
High-efficiency bevel gear drive	- High break away torque
High system efficiency incl. frequency converter	- Save money and energy – up to 25% power savings compared to conventional systems
Permanent-magnet three-phase synchronous motor	- Better than Super Premium Efficiency class IE4
Motor without cooling fins and fans	- Ensure a measurable reduction of airborne germs
10-pole motor for continuous duty S1	- High torque available
Available hollow shaft diameters: 30, 35 and 40 mm	- Flexible adaption to customer standards
Completely smooth enclosure leaves no crevices or dirt traps	- Easy to clean - Safe production
Motor and resolver connection with Danfoss CleanConnect® stainless steel circular connector (OGD Hygienic)	- Safe connection in wet areas - Fast replacement - High cleanability
Motor, resolver and brake connections via terminal box with CageClamp® technology (OGD Standard)	- Fast, reliable connection - Lower installation cost
Aseptic coating (standard for OGD Hygienic, optional for OGD Standard)	- Resistant to cleansing agents and disinfectants (pH 2..12)
Optional Antibac® antibacterial coating	- Reduced cleaning time and costs
Surface coating and food grade lubricants compliant with FDA and NSF requirements (OGD Hygienic)	- Reliable and direct use in product handling areas
High degrees of protection: - IP 67 and IP 69K (OGD Hygienic) - IP 65 and IP 67 (OGD Standard)	- Unrestricted use in wash down areas - High protection in wash down areas
<b>In combination with VLT® AutomationDrive FC 302 or VLT® Decentral Drive FCD 302</b>	
System voltage 380 ... 500 V +/-10%	- Widely usable
System frequency 50/60 Hz	- Available as central and decentral solution
Output frequency 0 – 250 Hz	- Wide speed control range
Operation with or without speed feedback (resolver option)	- Open loop operation for typical conveyor applications - Resolver option allows closed loop operation and synchronising/positioning applications

## Product range

- Power rating .....1.5 – 3 kW
- Max speed ..... 3000 RPM @ 250 Hz
- Frequency ..... max. 250 Hz
- Current..... max. 7.2 A

## Constants

- Torque.....  $k_t \approx 1,7 \text{ Nm/A}$
- Voltage .....  $k_c = 120 \text{ V/1000 rpm}$



## VLT® OneGearDrive Hygienic™

The OneGearDrive Hygienic™ complies with the requirements for best cleaning and hygienic design – with certification according to EHEDG (European Hygienic Engineering & Design Group).

It is certified as usable for clean rooms and aseptic filling by IPA (Fraunhofer institute) according to the dedicated "Air Cleanliness Classification" DIN EN ISO 14644-1.

The OneGearDrive is designed to be integrated in the plant equipment and to withstand the same cleaning agents and physical cleaning as the rest of the aseptic production equipment.

## Speed/ torque characteristics for gear ratios $i = 31.13; i = 14.13$ and $i = 8.12$ (max 3.0 kW)

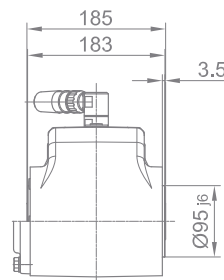
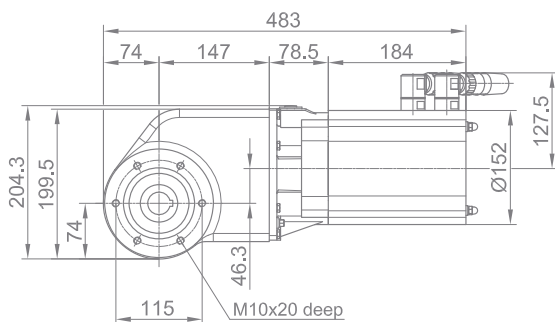
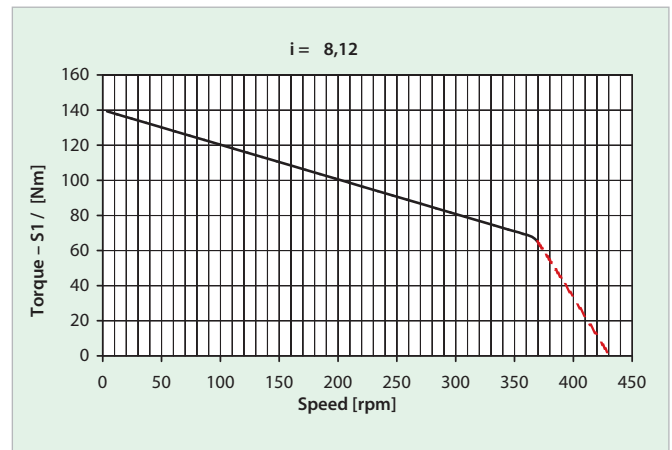
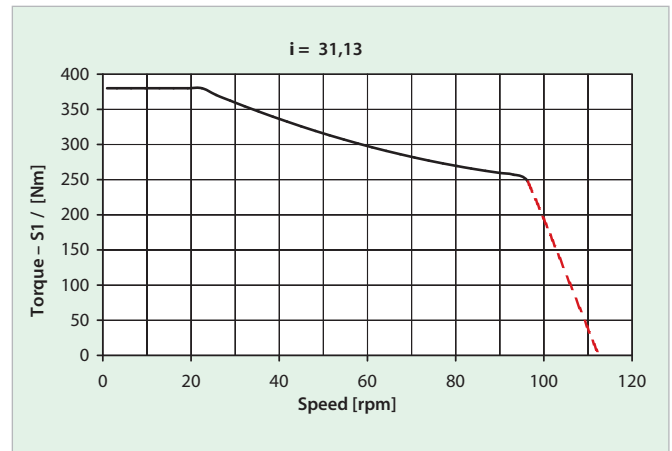
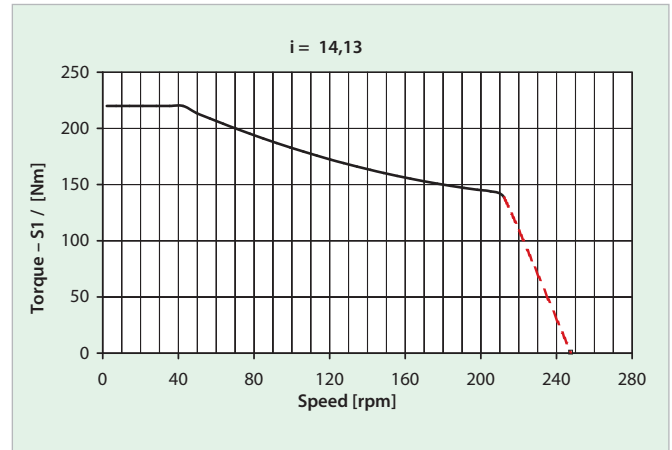

Dimensions of Danfoss VLT® OneGearDrive Hygienic™

# VLT® Integrated Servo Drive



## Perfect

match for:

- Remote drive applications
- Dynamic applications

The VLT® Integrated Servo Drive ISD is a permanent magnet based servo motor drive system for applications where high flexibility and dynamics are required. The servo drive is driven group wise by DC power supplies.

Permanent magnet synchronous servo motor is designed as a direct drive. Motor and electronics are integrated in one housing.

### Flexibility

The ISD servo drive fulfill requirements from high machine complexity, a variable number of axes and a modular machine structure.

### Regulation of the compact drives

An important aspect is the integration of motion control in the compact servo motors. Several axes and complex patterns of movements can be realized.

Feature	Benefit
Servo performance	Fast and accurate
Multi setup	Reduced machine setup
Compact servo drive	Cost reduced
Hybridcable	Easy installation
Decentral servo drive	Reduced installation

### DC Power supply

The power supply for the ISD system is 300 V DC. The ISD has extensive Power Supply opportunities and offers in addition a CAN interface. The maximum power output is rated 10 A, max power is 3.0 KW. Front-mounted LED's indicate operating state.

### Connection Box

The Connection Box provides the link between the power-supply and the ISD decentralized servo drives. The DC supply voltage and fieldbus bus are combined in a hybrid cable.

The C-Box is available in a basic version with all features and a comfort version with a built-in display for extensive diagnostic support.

### Encoder Box

The Encoder represents the encoder values of incremental or SSI encoders via a CAN bus directly to the ISD drives.

### Power range

Rated torque from 2.0 to 3.0 Nm  
Supply: 300 V DC

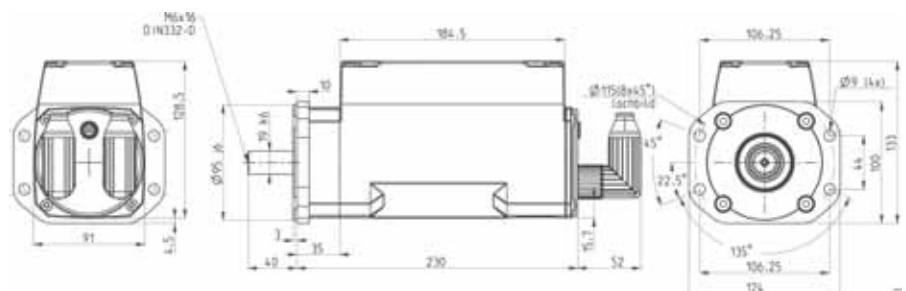

The ISD master system is necessary to control the integrated servo motors. The system is DC-driven network connected through a common master computer control.

The electronics in the servo drives, complete decentralized drives, are connected to the motor part in a common housing.

Multiple drives are combined through a hybrid cable that carries both the DC power and the CAN communication. This approach has significant advantages in installation and has a positive effect on the energy balance through the use of synchronous servo motors.

The control system consists of an embedded Power PC with a CoDeSys runtime system operating under Linux. It is controlled through a 5.7" VGA touch screen. It has 64 MB RAM and 16 MB flash memory.

The actual programming of the compact drive is enabled through the standard programming standard IEC 61131-3.

The software is designed so that basic functions such as reading and writing data to the individual servos, but also cam functionality are the building blocks. Also customer-specific master computers are used.

### Regulation of the ISD drives

An important aspect is the integration of motion control in the local control. All relevant controller information is promptly calculated in the DSP of the servo. To control a curve sequence the coefficients of several fifth-order polynomials are transferred to the drive via CAN bus.

### Specifications

Ordering number	175G7802	175G7804	175G7806	175G7808
Resolver	x	x	x	x
Break		9 Nm		9 Nm
Voltage [V <sub>DC</sub> ]	300 V DC	300 V DC	300 V DC	300 V DC
Stall torque [Nm]	2.8	2.8	3.2	3.2
Nominal torque [Nm]	2.4	2.4	2.6	2.6
Max. torque [Nm]	8	8	13	13
Current at stall torque [A <sub>DC</sub> ]	0.25	0.3	0.25	0.3
Nominal current [A <sub>DC</sub> ]	0.7	0.75	1.1	1.15
Max. current [A <sub>DC</sub> ]	3.6	3.65	8	8.05
Nominal speed [U/min]	600	600	1000	1000
Max. speed [U/min]	1200	1200 </td <td>2000</td> <td>2000</td>	2000	2000
Nominal load (P <sub>on</sub> ) [W]	210	225	330	345
Number of pole pairs [p]	8	8	8	8
Torque constant [Nm/A]	2.8	2.8	1.8	1.8
Voltage constants [V/1000rpm]	94	94	61	61
Enertia torque [kgm <sup>2</sup> ]	0,0006		0,0009	
Weight [kg]	6	7	6	7
Shaft diameter [mm]	19	19	19	19
Max. radial force [N]	1200 N	1200 N	1200 N	1200 N
Enclosure	IP 54/IP 65	IP 54/IP 65	IP 54/IP 65	IP 54/IP 65

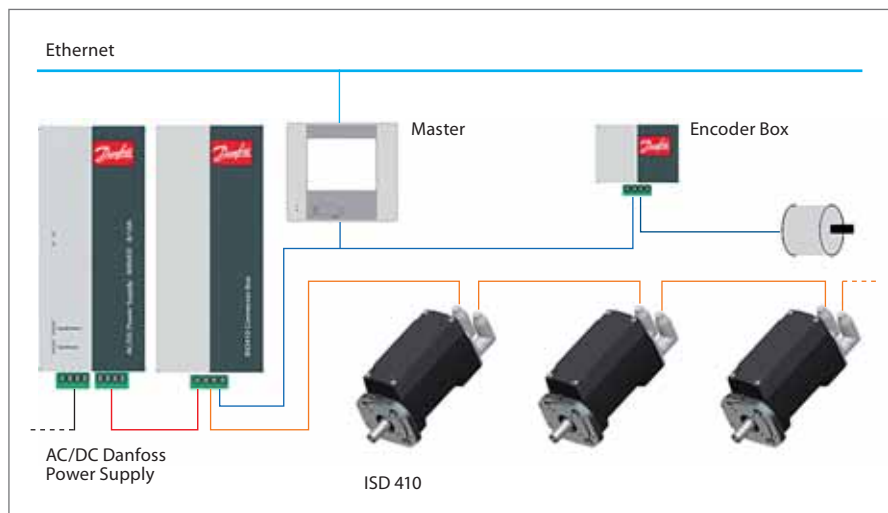

# VLT® Soft Starter MCD 500



## Perfect

match for:

- Pumps
- Conveyors
- Fans
- Mixers
- Compressors
- Centrifuges
- Mills
- Saws, and many more

VLT® Soft Starter MCD 500 is a total motor starting solution. Current transformers measure motor current and provide feedback for controlled motor ramp profiles.

AAC, Adaptive Acceleration Control, automatically employs the best starting and stopping profile for the application.

Adaptive Acceleration Control means, that for each start and stop, the soft starter compares and adapts the process to the chosen profile fitting to the application.

VLT® Soft Starter MCD 500 has a four line graphical display and a logic keypad making programming easy. Advanced setup is possible displaying operational status.

Three menu systems: Quick Menu, Application Setup and Main Menu provide optimum programming approach.

### Power range

21 – 1600 A, 7.5 – 850 kW  
(1.2 MW inside Delta Connection)  
Versions for 200 – 690 VAC

Feature	Benefit
AAC Adaptive Acceleration Control	- Automatically adapts to the chosen starting and stopping profile
Adjustable bus bars allow for both top and bottom entry (360–1600 A, 160–850 kW)	- Space saving, less cable cost and easy retrofitting
DC injection braking distributed evenly over three phases	- Less installation cost and less stress on the motor
Inside Delta (6-wire connection)	- Smaller soft starter can be selected for the application
Log menus, 99 events and trip log provide information on events, trips and performance	- Eases analysis of the application
Auto Reset	- Less down-time
Jog (slow-speed operation)	- Application flexibility
Second-order thermal model	- Allows motors to be used to their full potential without damage from overloading
Internal bypass contactors (21–215 A, 7.5–110kW)	- Saves space and wiring compared to external bypass - Very little heat dissipates when running. Eliminates costly external fans, wiring or bypass contactors
Auto-start/stop clock	- Application flexibility
Compact size – amongst the smallest in their class	- Saves space in cabinets and other application setups
4-line graphical display	- Optimum programming approach and setup for viewing operational status
Multiple programming setup (Standard Menu, Extended Menu, Quick Set)	- Simplifies the programming, but still holding to maximum flexibility
Multiple languages	- Serving the whole world

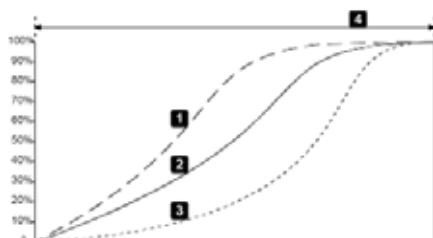

AAC Profiles

## Fully featured Soft Starter for motors up to 850 kW

- Total motor starting solution
- Advanced start, stop and protection features
- Adaptive Acceleration Control
- Inside Delta connection
- 4-line graphical display
- Multiple programming setup menus

## Optional

- Modules for serial communication:
  - DeviceNet
  - Profibus
  - Modbus RTU
  - USB
- Remote operator kit
- PC software:
  - WinMaster
  - MCT10



## Remote operation kit

- Start/stop, reset
- LED for start, run, trip
- Trip codes
- Current display
- Motor temperature display
- 4 – 20 mA output

## Specifications

Mains voltage (L1, L2, L3)	
MCD5-xxxx-T5	200 VAC ~ 525 VAC (± 10%)
MCD5-xxxx-T7	380 VAC ~ 690 VAC (± 10%)
MCD5-xxxx-T7	380 VAC ~ 600 VAC (± 10%) (inside delta connection)
Control voltage (terminals A4, A5, A6)	
CV1 (A5, A6)	24 VAC/VDC (± 20%)
CV2 (A5, A6)	110~120 VAC (+ 10% / - 15%)
CV2 (A4, A6)	220~240 VAC (+ 10% / - 15%)
Mains frequency	50/60 Hz (± 10%)
Rated insulation voltage to earth	600 VAC
Rated impulse withstand voltage	4 kV
Form designation	Bypassed or continuous, semiconductor motor starter form 1
Short circuit capability	
Coordination with semiconductor fuses	Type 2
Coordination with HRC fuses	Type 1
MCD500-0021B to 0215B	Prospective current of 65 kA
MCD500-0245C	Prospective current of 85 kA
MCD500-1200C to 1600C	Prospective current of 100 kA
Electromagnetic capability (compliant with EU Directive 89/336/EEC)	
EMC Emissions (Terminals 13 & 14)	IEC 60947-4-2 Class B and Lloyds Marine No. 1 Specification
EMC Immunity	IEC 60947-4-2
Outputs	
Relay Outputs	10A @ 250 VAC resistive, 5A @ 250 VAC AC15 pf 0.3
Programmable Outputs	
Relay A (13, 14)	Normally open
Relay B (21, 22, 24)	Changeover
Relay C (33, 34)	Normally open
Analogue Output (07, 08)	0 – 20 mA or 4 – 20 mA (selectable)
Maximum load	600 Ω (12 VDC @ 20 mA) (accuracy ± 5%)
24 VDC Output (16, 08) Maximum load	200 mA (accuracy ± 10%)
Environmental	
Protection MCD5-0021B ~ MCD5-0105B	IP 20 & NEMA, UL Indoor Type 1
Protection MCD5-0131B ~ MCD5-1600C	IP 00, UL Indoor Open Type
Operating temperature	-10° C to 60° C, above 40° C with derating
Storage temperature	-25° C to + 60° C
Operating Altitude	0 – 1000 m, above 1000 m with derating
Humidity	5% to 95% Relative Humidity
Pollution degree	Pollution Degree 3
Heat Dissipation	
During start	4.5 watts per ampere

## Dimensions

Current rating [A]	Weight [kg]	Height [mm]	Width [mm]	Depth [mm]	Frame size
21, 37, 43 and 53	4.2	295	150	183	G1
68	4.5			213	
84, 89 and 105	4.9	438	275	250	G2
131, 141, 195 and 215	14.9			279	
245	23.9	460	390	279	G3
360, 380 and 428	35	689	430	302	G4
595, 619, 790 and 927	45			364	
1200, 1410 and 1600	120	856	585	364	G5

# VLT® Compact Starter MCD 200



## Perfect

match for:

- Pumps
- Fans
- Compressors
- Mixers
- Conveyors
- and many more

The VLT® Compact Starter MCD 200 from Danfoss includes two families of soft starters in the power range from 7.5 to 110 kW.

The series offer easy DIN rail mounting for sizes up to 30 kW, 2-wire or 3-wire start/stop control and excellent starting duty ( $4 \times I_e$  for 6 seconds).

Heavy starting ratings at  $4 \times I_e$  for 20 seconds.

Compatible with grounded delta power systems.

**Power range**  
7.5 – 110 kW

Feature	Benefit
Small footprint and compact size	- Saves panel space
Built-in bypass	- Minimises installation cost and eliminates power loss - Reduces heat build up. Savings in components, cooling, wiring and labor
Advanced accessories	- Allows enhanced functionality
Advanced SCR Control Algorithms balances output waveform	- Allowing more starts per hour, accepting higher load
<b>User friendly</b>	<b>Save commissioning and operating cost</b>
Easy to install and use	- Saves time
Easy DIN rail mounting for sizes up to 30 kW	- Saves time and space
<b>Reliable</b>	<b>Maximum uptime</b>
Essential motor protections (MCD 202)	- Reduces overall project investment
Max. ambient temperature 50° C without derating	- No external cooling or oversizing necessary

### MCD 201

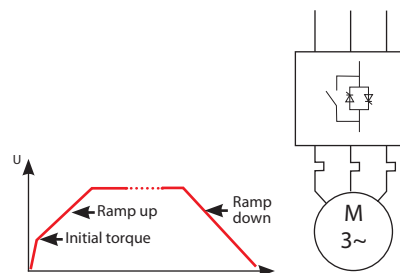

### MCD 202

MCD 202 provides enhanced soft start functionality and various motor protection features

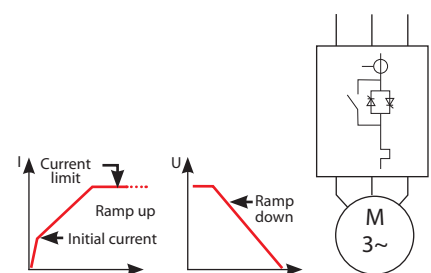

## Soft Starter for motors up to 110 kW

- Total motor starting solution
- Start, stop and protection features
- Local programming keypad and display

### Optional

- Modules for serial communication:
  - DeviceNet
  - Profibus
  - Modbus RTU
  - USB
- Remote operator kit
- PC software
- Pump application module



### Remote operation kit

Remote Operator and display with 4–20 mA analogue output proportional to motor current (MCD 202)  
 Serial communication: Modbus RTU, AS-i, Profibus and DeviceNet.  
 PC-based MCD set-up software.

## Specifications

Mains supply (I1, L2, L3)	
Supply voltage	3 x 200 VAC – 440 VAC or 3 x 200 – 575 VAC
Supply frequency	45 – 66 Hz
Control voltage	100 – 240 VAC 380 – 440 VAC 24 VDC/24 VAC
Control inputs	
Control inputs	Start, Stop Reset upsh button on the unit
Relay outputs	
Relay outputs	1 x main contactor 1 x programmable* (Trip or Run)
Protections, MCD 201	
	Phase sequence Supply fault Shorted SCR
Protections, MCD 202	
	Motor thermistor input Motor temperature – thermal model Phase imbalance Phase sequence Excess start time Supply fault Shorted SCR
LED indications	
Indications	Ready/Fault Run
Ambient operating temperature	
Ambient temperature	-5 to 60°C (above 40°C without derating)
Standards approvals	
Approvals	CE, UL, C-UL, CCC, C-tick, Lloyds

## Cabinet sizes

Power range (400 V)	7 – 30 kW	37 – 55 kW	75 – 110 kW
Height [mm]	203	215	240
Width [mm]	98	145	202
Depth [mm]	165	193	214

# VLT® Soft Starter MCD 100



## Perfect

match for:

- Smaller compressors for example scroll or reciprocating compressors in air-conditioning units
- Conveyor systems
- Pumps

MCD 100 is a cost effective and extremely compact soft starter for AC motors.

A true “fit and forget” soft starter for DIN rail mount MCD 100 provides basic soft start and stop function.

- A robust semiconductor design
  - selection can be based on motor power which ensures easy selection.
- Can be used for an almost unlimited number of starts per hour without derating.
- A universal control voltage (24-480 V AC/ V DC) – simplifies selection and keeps stock at a minimum.
- A “fit and forget” contactor design – simplifies installation and reduces required panel space.
- Digitally controlled rotary switches – secures precise settings and simplifies installation.
- Ratings for heavy duty as standard – simplifies installation and reduces the risk of breakdown

Feature	Benefit
Small footprint and compact size	- Saves panel space
Selection can be based on motor power	- Easy selection
Universal control voltage	- Simplifies selection - Keeps stock at a minimum
“Fit and forget” contactor design	- Simplifies installation - Reduces required panel space
<b>User friendly</b>	<b>Save commissioning and operating cost</b>
Easy to install and use	- Saves time
Digitally controlled rotary switches	- Secures precise settings and simplifies installation
Easy DIN rail mounting for sizes up to 30 kW	- Saves time and space
<b>Reliable</b>	<b>Maximum uptime</b>
Robust semiconductor design	- Reliable operation
Almost unlimited number of starts per hour without derating	- Prevents unauthorized changes
Max. ambient temperature 50° C without derating	- No external cooling or oversizing necessary

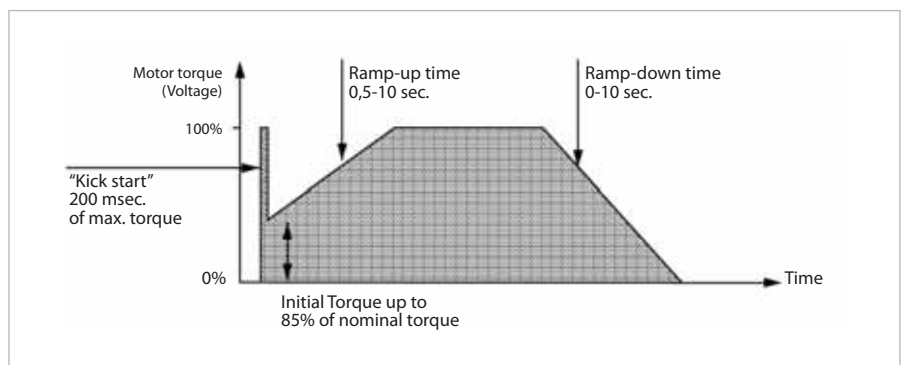

## Timed voltage ramp

- Micro Soft Start Controller for motors up to 11 kW
- Extremely robust SCR design with heavy ratings as standard
- Unlimited number of starts per hour
- Contactor style design for easy selection, installation and commissioning

## Power range

MCD 100-001 .....	1,5 kW
MCD 100-007 .....	7.5 kW
MCD 100-011 .....	11 kW

All sizes are rated for line voltage up to 600 V AC.

## Specifications

Mains supply (L1, L2, L3)	
MCD 100	3 x 208 VAC ~ 600 VAC (+10% / -15%)
Supply frequency (at start)	45 Hz – 66 Hz
Control circuit (A1, A2)	
MCD 100	24 – 480 VAC/VDC (-15% +10%)
Environmental	
Degree of protection MCD 100	IP 20
Operating temperatures	-5° C/+40° C (60° C with de-rating)
Pollution Degree	Pollution Degree 3
EMC Emission	
Equipment class (EMC)	Class A
Conducted radio frequency emission	
0.15 MHz – 0.5 MHz	< 90 dB (µV)
0.5 MHz – 5 MHz	< 76 dB (µV)
5 MHz – 30 MHz	80-60 dB (µV)
Radiated radio frequency emission	
30 MHz – 230 MHz	< 30 dB (µV/m)
230 MHz – 1000 MHz	< 37 dB (µV/m)

*This product has been designed for Class A equipment. Use of the product in domestic environments may cause radio interference, in which case the user may be required to employ additional mitigation methods.*

EMC Immunity	
Electro static discharge	4 kV contact discharge, 8 kV air discharge
Radio-frequency electromagnetic field	
0.15 MHz – 1000 MHz	140 dB (µV)
Rated impulse withstand voltage (Fast transients 5/50 ns – Burst)	4 kV line to earth
Rated insulation voltage (Surges 1.2/50 µs – 8/20 µs)	4 kV line to earth, 2 kV line to line
Voltage dip and short time interruption	100 ms (at 40% nominal voltage)
Short Circuit	
Rated short-circuit current MCD 100-001	Normal fuses: 25 A gL/gG
SCR I2t rating for semiconductor fuses	72 A2s
Rated short-circuit current MCD 100-007	Normal fuses: 50 A gL/gG
SCR I2t rating for semiconductor fuses	1800 A2s
Rated short-circuit current MCD 100-011	Normal fuses: 80 A gL/gG
SCR I2t rating for semiconductor fuses	6300 A2s
Heat Dissipation	
MCD 100-001	Max. 4 watts
MCD 100-007 to MCD 100-011	2 watts/Ampere
Standards Approvals	
UL/C-UL	UL508
CE	IEC 60947-4-2

## Dimensions

Model	Power size (kW)	Rated current (Amps)	Dimensions (mm) H x W x D	Approvals
MCD100	1.5	3 A: 5-5:10 (AC 53b)	102x22,5x124	UL, CSA, CE
	7.5	15 A: 8-3: 100-3000 (AC 53a)	110x45x128	
	11	25 A: 6-5:100-480 (AC 53a)	110x90x128	

# VLT® Low Harmonic Drive



## Optimised

for:

- VLT® HVAC Drive FC 102
- VLT® AQUA Drive FC 202
- VLT® AutomationDrive FC 302

The Danfoss VLT® Low Harmonic Drive is the first solution combining an active filter and a drive in one package.

The VLT® Low Harmonic Drive continuously regulates harmonic suppression according to the load and grid conditions without affecting the connected motor.

The Total Harmonic Current Distortion is reduced to less than 3% at ideal conditions and to less than 5% at heavy distortion grids with up to 2% phase unbalance. As individual harmonics also fulfil toughest harmonic requirements, the VLT® Low Harmonic Drive meets all present harmonic standards and recommendations.

Unique features such as sleep mode and back channel cooling offers unmatched energy efficiency for Low Harmonic Drives.

The VLT® Low Harmonic Drive requires the same set-up and installation as a standard VLT® drive and out of the box it ensures optimum harmonic performance.

The VLT® Low Harmonic Drive has the same modular build-up as our standard high power drives and shares similar features: Built-in RFI filters, coated PCB and user-friendly programming.

Feature	Benefit
<b>Reliable</b>	<b>Maximum uptime</b>
- No increased winding stress on motor	- Longer motor lifetime
- 100% factory tested	- Less initial cost (no output filter needed)
- Coated PCBs	- Low failure rate
- Innovative cooling concept	- Prolonged lifetime of electronics
<b>User-friendly</b>	<b>Saves commissioning and operating cost</b>
- No extra wiring and set-up needed	- Easy commissioning and low initial costs
- Modular design	- Easy serviceability
- Full readout of grid conditions	- Reduces needed harmonic testing
<b>Energy saving</b>	<b>Lower operation costs</b>
- High efficiency	- Low running expenses
- Sleep mode and progressive switching freq.	- Increased transformer efficiency
- Independent of grid and load changes	- Reduced cable losses

### Voltage range

- 380 – 480 V AC 50 – 60 Hz

### Power Range

132 – 630 kW High Overload/  
160 – 710 kW Normal Overload  
(Matching drive frames D, E and F)

### Enclosure degree

- IP 21/NEMA 1
- IP 54/NEMA 12

## Options

The following options are available:

- RFI filters
- Disconnect
- Fuses
- Mains shielding
- Feedback and I/O options
- Fieldbus options
- dU/dt filters
- Sine wave filters

## PC software

### VLT® MCT 10 Setup Software

VLT® MCT 10 offers advanced programming functionality for all Danfoss drive products, greatly reducing programming and set-up time.

VLT® MCT 10 Basic (available free of charge from [www.danfoss.com](http://www.danfoss.com)) allows access to a finite number of drives with limited functionality. The advanced edition, offering a higher level of functionality, is available from your Danfoss sales partner.

### VLT® MCT 31 Harmonics Calculation Software

With VLT® MCT 31, you can determine whether harmonics will be an issue in your installation when drives are added.

VLT® MCT 31 estimates the benefits of adding various harmonic mitigation solutions from the Danfoss product portfolio and calculates system harmonic distortion. Furthermore the software provides quick indication of whether the installation complies with the most recognised harmonic norms and recommendations.

From [www.danfoss.com](http://www.danfoss.com) you can download the free tool VLT® Harmonic Calculation MCT 31 – the most up-to-date version of the calculation software.

## Specifications

THiD* at:	
- 40% load	< 5,5%
- 70% load	< 3,5%
- 100% load	< 3%
Efficiency* at:	
- 40% load	> 93%
- 70% load	> 95%
- 100% load	> 96%
True power factor* at:	
- 40% load	> 98%
- 70% load	> 98%
- 100% load	> 98%
Ambient temperature	40° C without derating
Cooling	Back-channel air cooling

\* Measured at balanced grid without pre-distortion

Norms and recommendations	Compliance
IEEE519	Always
IEC61000-3-2 (up to 16 A)	Out of scope
IEC61000-3-12 (between 16 and 75 A)	Out of scope
IEC61000-3-4 (above 75 A)	Always



400 VAC (380 – 460 VAC)										
Normal Overload			High Overload			Frame	Dimensions		Weight	
Power	Current		Power	Current			H x W x D			
kW	HP	[A]	kW	HP	[A]			IP 21	kg	lbs
160	250	315	132	200	260	D13	1740 x 1020 x 380 mm 68.5 x 49.6 x 14.9 inches	306.6	676	
200	300	395	160	250	315			306.6	676	
250	350	480	200	300	395			306.6	676	
315	450	600	250	350	480	E9	2000 x 1200 x 500 mm 78.7 x 56.7 x 19.7 inches	676.2	1491	
355	500	658	315	450	600			676.2	1491	
400	625	745	355	500	658			676.2	1491	
450	700	800	400	625	695			676.2	1491	
500	780	880	450	700	800	F18	2200 x 2800 x 600 mm 86.6 x 145.6 x 23.6 inches	1899	4187	
560	875	990	500	780	880			1899	4187	
630	985	1120	560	875	990			1899	4187	
710	1100	1260	630	985	1120			1899	4187	

# VLT® 12-pulse drive

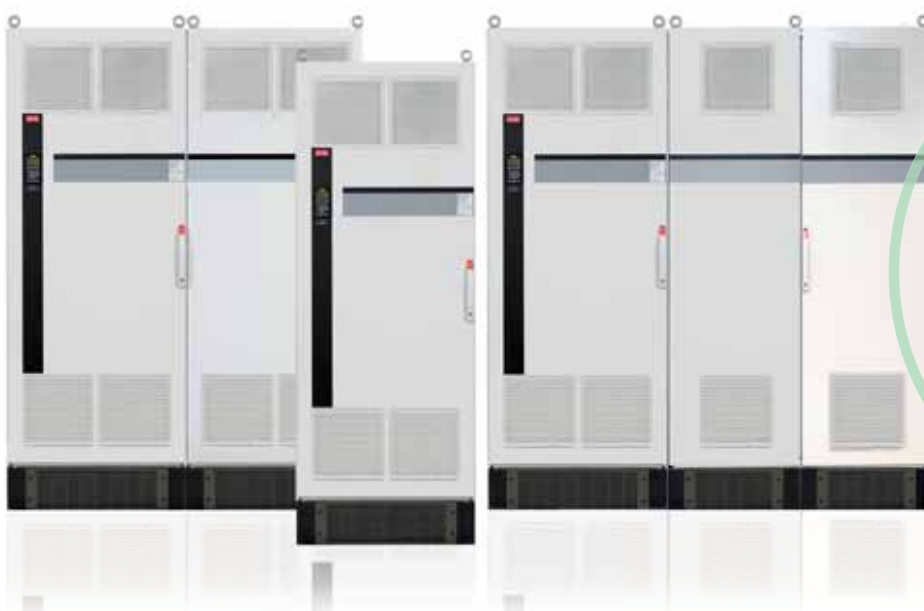

## Optimised

for:

- VLT® HVAC Drive FC 102
- VLT® AQUA Drive FC 202
- VLT® AutomationDrive FC 302

Robust and cost effective harmonic solution for the higher power range. The Danfoss VLT® 12-pulse drive offers reduced harmonics for demanding industry applications above 250 kW.

The VLT® 12-pulse is a high efficiency variable frequency converter which is built with the same modular design as the popular 6-pulse VLT® drives. It is offered with similar drive options and accessories and can be configured according to customer need.

Together with the needed 30°-phase shifting transformer the solution provides durability and reliability at a low cost.

Under ideal grid conditions the solution eliminates the 5<sup>th</sup>, 7<sup>th</sup>, 17<sup>th</sup> and 19<sup>th</sup> harmonics and results in a THiD of around 12% at full load.

The needed transformer makes this solution ideal for applications where stepping down from medium voltage is required or where isolation from the grid is needed.

The Danfoss VLT® 12-pulse drive provides harmonic reduction without adding capacitive or inductive components which often require network analysis to avoid potential system resonance problems.

Feature	Benefit
<b>Reliable</b>	<b>Maximum uptime</b>
- Maintenance free	- No running expenses
- Durability	- Long lifetime
- Coated PCBs	- Environmental robustness
- 100% factory tested	- Low failure rate
- Back-channel cooling	- Prolonged lifetime of electronics
<b>Design</b>	<b>Easy operation and user-friendly set-up</b>
- Modular design	- Easy serviceability
- Same easy programming as a 6-pulse drive	- User-friendly operation
- Standard award-winning control panel (LCP)	- Effective commissioning and operation
- Available in 27 languages	

### Power Range

- 250 kW – 1.4 MW

### Voltage Range

- 380 – 690 V

### Enclosure

- IP 21/NEMA Type 1
- IP 54/NEMA Type 12

### Options

The following options are available:

- RFI filters
- Disconnect
- Fuses
- Mains shielding
- Feedback and I/O options
- Fieldbus options
- dU/dt filters
- Sine wave filters

## PC software VLT® MCT 10 Setup Software

VLT® MCT 10 offers advanced programming functionality for all Danfoss drive products, greatly reducing programming and set-up time.

VLT® MCT 10 Basic (available free of charge on [www.danfoss.com](http://www.danfoss.com)) allows access to a finite number of drives with limited functionality. The advanced edition, offering a higher level of functionality, is available from your Danfoss sales partner.

## VLT® MCT 31 Harmonics Calculation Software

With VLT® MCT 31 you can determine whether harmonics will be an issue in your installation when drives are added.

VLT® MCT 31 estimates the benefits of adding various harmonic mitigation solutions from the Danfoss product portfolio and calculates system harmonic distortion.

From [www.danfoss.com](http://www.danfoss.com) you can download the free tool VLT® Harmonic Calculation MCT 31.

## Specifications

THiD* at:	
- 40% load	20%
- 70% load	14%
- 100% load	12%
Efficiency* at:	
- 40% load	95%
- 70% load	97%
- 100% load	98%
True power factor* at:	
- 40% load	91%
- 70% load	95%
- 100% load	97%
Ambient temperature	45° C without derating
Cooling	Back-channel air cooling

\* Measured at balanced grid without pre-distortion

Norms and recommendations	Compliance
IEEE519	Depends on grid and load conditions
IEC61000-3-2 (up to 16 A)	Out of scope
IEC61000-3-12 (between 16 and 75 A)	Out of scope
IEC61000-3-4 (above 75 A)	Always

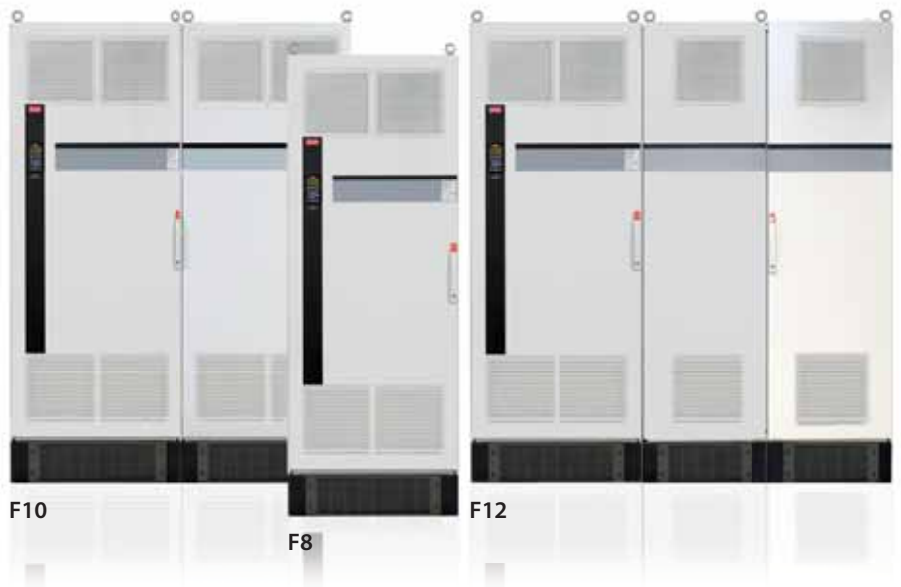

400 V AC				460 V AC				690 V AC				Frame	Dimensions HxWxD IP 21 [mm]
Normal Overload		High Overload		Normal Overload		High Overload		Normal Overload		High Overload			
Power [kW]	Current [A]	Power [kW]	Current [A]	Power [HP]	Current [A]	Power [HP]	Current [A]	Power [kW]	Current [A]	Power [kW]	Current [A]		
315	600	250	480	450	540	350	443	400	450	355	380	F8	2280 x 800 x 607
355	648	315	600	500	590	450	540	500	500	400	410	F9 w. options cabinet	2280 x 1400 x 607
400	745	355	658	550	678	500	590	560	570	500	500		
450	800	400	695	600	730	550	678	630	630	560	570	F10	2280 x 1600 x 607
500	880	450	800	650	780	600	730	710	730	630	630	F11 w. options cabinet	2280 x 2200 x 607
560	990	500	880	750	890	650	780	800	850	710	730		
630	1120	560	990	900	1050	750	890	900	945	800	850	F12	2280 x 2000 x 607
710	1260	630	1120	1000	1160	900	1050						
800	1460	710	1260	1200	1380	1000	1160	1000	1060	900	945	F13 w. options cabinet	2280 x 2600 x 607
1000	1720	800	1460	1350	1530	1200	1380	1200	1260	1000	1160		
								1400	1415	1200	1260		

# VLT® Advanced Active Filter AAF 006



A flexible and adaptable solution for central or de-central harmonic mitigation.

Danfoss Advanced Active Filters can compensate for individual VLT® drives or can be installed as a compact stand-alone solution at a common point of coupling, compensating for several loads simultaneously.

Consequently the filter ensures optimal harmonic suppression independent of the number of loads and their individual load profile. In addition the active filter corrects the power factor and balances the phase load providing an optimal energy utilization.

This improves the system efficiency and increases the grid robustness to avoid downtime.

The extensive re-use of proven VLT® components and the modular construction ensures a high reliability and at the same time offers high energy efficiency, back channel cooling and high enclosure grades without size increase.

The VLT® Advanced Active Filter is easily controlled via the user-friendly LCP, sharing design and programming structure with the VLT® drives series.

Feature	Benefit
<b>Reliable</b>	<b>Maximum uptime</b>
<ul style="list-style-type: none"> <li>- 100% factory tested</li> <li>- Coated PCBs</li> <li>- &gt;90% components re-used from proven VLT® FC series</li> </ul>	<ul style="list-style-type: none"> <li>- Low failure rate</li> </ul>
<ul style="list-style-type: none"> <li>- Innovative cooling concept</li> </ul>	<ul style="list-style-type: none"> <li>- Prolonged lifetime of electronics</li> </ul>
<b>User-friendly and flexible</b>	<b>Saves commissioning and operating cost</b>
<ul style="list-style-type: none"> <li>- Innovative programming possibilities</li> <li>- Modular design</li> </ul>	<ul style="list-style-type: none"> <li>- Low running expenses</li> <li>- Easy serviceability</li> </ul>
<ul style="list-style-type: none"> <li>- Wide range of options</li> </ul>	<ul style="list-style-type: none"> <li>- Low initial investment</li> <li>- High degree of customisation</li> </ul>
<b>Energy saving</b>	<b>Lower operation costs</b>
<ul style="list-style-type: none"> <li>- High efficiency</li> <li>- Sleep mode and progressive switching freq.</li> <li>- Power factor correction</li> </ul>	<ul style="list-style-type: none"> <li>- Low running expenses</li> </ul>

Without dismantling existing installation, the VLT® Advanced Active Filters are easily retrofitted to the existing installation, where harmonics are increased because of enlarged employment of non-linear loads such as variable speed drives.

**Voltage range**  
380 – 480 V AC 50 – 60 Hz

**Current range**  
190 A, 250 A, 310 A, 400 A.  
Up to 4 units can be paralleled for higher power.

**Enclosure degree**  
■ IP 21/NEMA Type 1  
■ IP 54/NEMA Type 12

## Options

The following options are available:

- RFI filters
- Disconnect
- Fuses
- Mains shielding

## PC software

### VLT® MCT 10 Setup Software

VLT® MCT 10 offers advanced programming functionality for all Danfoss drive products, greatly reducing programming and set-up time.

VLT® MCT 10 Basic (available free of charge from [www.danfoss.com](http://www.danfoss.com)) allows access to a finite number of drives with limited functionality. The advanced edition, offering a higher level of functionality, is available from your Danfoss sales partner.

### VLT® MCT 31 Harmonics Calculation Software

With VLT® MCT 31, you can determine whether harmonics will be an issue in your installation when drives are added.

VLT® MCT 31 estimates the benefits of adding various harmonic mitigation solutions from the Danfoss product portfolio and calculates system harmonic distortion. Furthermore the software provides quick indication of whether the installation complies with the most recognised harmonic norms and recommendations.

From [www.danfoss.com](http://www.danfoss.com) you can download the free tool VLT® Harmonic Calculation MCT 31 – the most up-to-date version of the calculation software.

## Specifications

THiD* at:	
- 40% load	< 7%
- 70% load	< 5,5%
- 100% load	< 5%
Efficiency* at:	
- 40% load	> 95%
- 70% load	> 98%
- 100% load	> 98%
True power factor* at:	
- 40% load	> 0,98
- 70% load	> 0,98
- 100% load	> 0,98
Ambient temperature	45° C
Cooling	Back-channel air cooling

\* Measured at balanced grid without pre-distortion and with VLT® drive matching full load demand

Norms and recommendations	Compliance
IEEE519	Application and load dependent
IEC61000-3-2 (up to 16 A)	Out of scope
IEC61000-3-12 (between 16 and 75 A)	Out of scope
IEC61000-3-4 (above 75 A)	Out of scope



400 V AC (380 – 480 V AC)					
Total Current [A]	Max. Reactive [A]	Max. Harmonic [A]	Frame	Dimensions H x W x D mm [Inches]	Weight Kg [Lbs]
190	190	170	D14	1740 x 600 x 380 [68,2 x 33,5 x 15,0]	283 [623]
250	250	225	E1	2000 x 600 x 500 [78,7 x 33,5 x 19,4]	476 [1047]
310	310	280			498 [1096]
400	400	360			

Total Current [A]	Max. individual harmonic compensation [A]							
	I <sub>5</sub>	I <sub>7</sub>	I <sub>11</sub>	I <sub>13</sub>	I <sub>17</sub>	I <sub>19</sub>	I <sub>23</sub>	I <sub>25</sub>
190	119	85	55	48	34	31	27	24
250	158	113	72	63	45	40	36	32
310	196	140	90	78	56	50	45	40
400	252	180	115	100	72	65	58	50

# VLT® Advanced Harmonic Filter



## Perfect

match for:

- Industrial automation
- High dynamic applications
- Safety installations

Optimised harmonic performance with the VLT® FC series up to 250 kW.

The Danfoss Advanced Harmonic Filters have been specially designed to match the Danfoss frequency converters for unmatched performance and design.

Compared to traditional harmonic trap filters they offer a smaller foot print and higher harmonic reduction.

The solution is available in two variants, AHF 005 and AHF 010. When connected in front of a Danfoss VLT® frequency converter, the harmonic current distortion generated back to the mains is reduced to 5% and 10% Total Harmonic Current Distortion at full load.

With a >98% efficiency the passive Advanced Harmonic Filters offer cost effective and very robust harmonic solutions specifically for power up to 250 kW.

As stand-alone options the advanced harmonic filters feature a compact housing that is easily integrated into existing panel space. This makes them well-suited for retrofit applications with limited adjustments of the frequency converter.

Feature	Benefit
<b>Reliable</b>	<b>Maximum uptime</b>
<ul style="list-style-type: none"> <li>- 100% factory tested</li> <li>- Based on proven and tested filter concept</li> </ul>	<ul style="list-style-type: none"> <li>- Low failure rate</li> </ul>
<b>Energy saving</b>	<b>Lower operation costs</b>
<ul style="list-style-type: none"> <li>- High efficiency</li> <li>- Electrically matched to the individual VLT® FC drives</li> </ul>	<ul style="list-style-type: none"> <li>- Low running expenses</li> </ul>
<b>Design</b>	<b>Compact and aesthetic enclosure</b>
<ul style="list-style-type: none"> <li>- Innovative coil design</li> <li>- Side-by-side mounting</li> <li>- Optimized for mounting in panels</li> </ul>	<ul style="list-style-type: none"> <li>- Smaller footprint</li> <li>- Less wall space needed</li> </ul>
<ul style="list-style-type: none"> <li>- Easy commissioning</li> <li>- Enclosure size and colour matches</li> </ul>	<ul style="list-style-type: none"> <li>- Low commissioning costs</li> <li>- Danfoss look and feel</li> </ul>

### Line Voltage

- 380 – 415 V AC (50 and 60 Hz)
- 440 – 480 V AC (60 Hz)
- 500 – 525V (50 Hz)\*
- 690 V (50 Hz)\*

\* Existing range. Will be upgraded and released 3rd Quarter 2010.

### Filter current

- 10 A – 480 A (380 – 415 V, 50/60 Hz)
- 10 A – 436 A (440 – 480 V, 60 Hz)
- (Modules can be paralleled for higher power)

### Enclosure degree

- IP 20/IP 00

## Options

The following options are available:

- IP 21/NEMA 1 kit

## PC software

### VLT® MCT 10 Setup Software

VLT® MCT 10 offers advanced programming functionality for all Danfoss drive products, greatly reducing programming and set-up time.

VLT® MCT 10 Basic (available free of charge from [www.danfoss.com](http://www.danfoss.com)) allows access to a finite number of drives with limited functionality. The advanced edition, offering a higher level of functionality, is available from your Danfoss sales partner.

### VLT® MCT 31 Harmonics Calculation Software

With VLT® MCT 31, you can determine whether harmonics will be an issue in your installation when drives are added.

VLT® MCT 31 estimates the benefits of adding various harmonic mitigation solutions from the Danfoss product portfolio and calculates system harmonic distortion. Furthermore the software provides quick indication of whether the installation complies with the most recognised harmonic norms and recommendations.

From [www.danfoss.com](http://www.danfoss.com) you can download the free tool VLT® Harmonic Calculation MCT 31 – the most up-to-date version of the calculation software.

## Specifications

	AHF 010	AHF 005
THiD* at: – 40% load – 70% load – 100% load	~ 12% ~ 11% < 10%	~ 7% ~ 6% < 5%
Efficiency* at 100% load	>98.5%	
True power factor* at: – 40% load – 70% load – 100% load	~ 81% ~ 96% > 99%	~ 80% ~ 95% > 98%
Ambient temperature	45° C without derating	
Cooling	Back-channel air cooling	

\* Measured at balanced grid without pre-distortion

Norms and recommendations	Compliance
IEEES19	AHF 005 always AHF 010 depends on grid and load conditions
IEC61000-3-2 (up to 16 A)	Always
IEC61000-3-12 (between 16 and 75 A)	Always
IEC61000-3-4 (above 75 A)	Always

## Enclosures

380–415 V 50/60 Hz	440–480 V 60 Hz	Enclosure Type	
		AHF010	AHF005
10	10	X1	X1
14	14	X1	X1
22	19	X2	X2
29	25	X2	X2
34	31	X3	X3
40	36	X3	X3
55	48	X3	X3
66	60	X4	X4
82	73	X4	X4
96	95	X5	X5
133	118	X5	X5
171	154	X6	X6
204	183	X6	X6
251	231	X7	X7
304	291	X7	X7
325	355	X7	X7
381	380	X7	X8
480	436	X7	X8

## Dimensions

Enclosure Type	Dimensions in mm		
	A (height)	B (width)	C (depth)
X1	332	190	206
X2	450	232	248
X3	594	378	242
X4	624	378	333
X5	739	418	333
X6	778	418	596
X7	909	468	449
X8	911	468	543

# VLT® Common Mode Filters

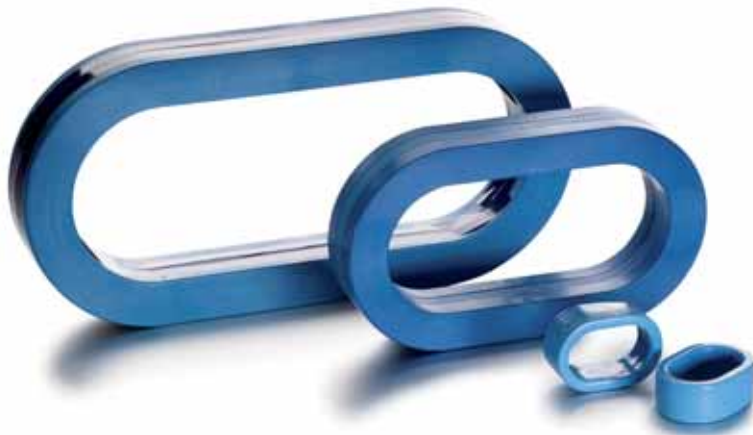

High-frequency common-mode core kit reduce electromagnetic interference and eliminate bearing damage by electrical discharge.

High-frequency common-mode (HF-CM) cores are special nanocrystalline magnetic cores which have superior filtering performance compared to regular ferrite cores. They act like a common-mode inductor (between phases and ground).

Installed around the three motor phases (U, V, W), they reduce high-frequency common-mode currents. As a result, high-frequency electromagnetic interference from the motor cable is reduced. However, the core kit should not be used as the sole mitigation measure, and even when the cores are used, the EMC installation rules shall be followed.

## Prevent motor bearing currents

The most important function is to reduce high-frequency currents associated with electrical discharges in the motor currents. These discharges contribute to the premature wear-out and failure of motor bearings. By reducing or even eliminating discharges, the wear-out of the bearings is reduced and the lifetime extended. Thus, maintenance and down-time costs are lowered.

Feature	Benefit
- High-performance nanocrystalline magnetic material	- Effective reduction of electrical discharges in the motor bearings - Reduces bearing wear-out, maintenance costs and down-time - Reduces high-frequency electromagnetic interference from the motor cable
- Oval shape - Scalable solution: longer cables handled by stacking more cores	- Easy to install in restricted places such as the VLT® enclosure or the motor terminal box
- Only 4 core sizes cover the entire VLT® power range	- Easy logistics, fast delivery and comprehensible product program - Allows the addition to a service tool-kit
- Low investment	- Cost-effective alternative to, for example, sine-wave filters if the only phenomena to be mitigated is bearing wear-out through electrical discharge

## Ideal for retrofitting

Bearing current problems are most often discovered after commissioning. Therefore, the cores have an oval shape which makes them ideal for retrofitting and for installation in restricted places.

Only 4 variants cover the entire VLT® product range making it possible to carry these valuable aids in a service tool kit.

## A flexible solution

The cores can be combined with other output filters, and especially in combination with dU/dt filters they offer a low cost solution for protection of both motor bearings and insulation.

## Product range

- Available for all power sizes from 0.18 kW to 1.4 MW
- 4 core sizes cover the entire VLT® power range

## HF-CM selector

The cores can be installed at the frequency converter's output terminals (U, V, W) or in the motor terminal box. When installed at the frequency converter's terminals, the HF-CM kit reduces bearing stress and high-frequency electromagnetic interference from the motor cable. The number of cores depends on motor cable length and frequency converter voltage. A selection table is shown to the right.

Cable length [m]	A and B frame		C frame		D frame		E and F frame	
	T5	T7	T5	T7	T5	T7	T5	T7
50	2	4	2	2	2	4	2	2
100	4	4	2	4	4	4	2	4
150	4	6	4	4	4	4	4	4
300*	4	6	4	4	4	6	4	4

\* Longer cable lengths are easily handled by stacking more HF-CM cores.

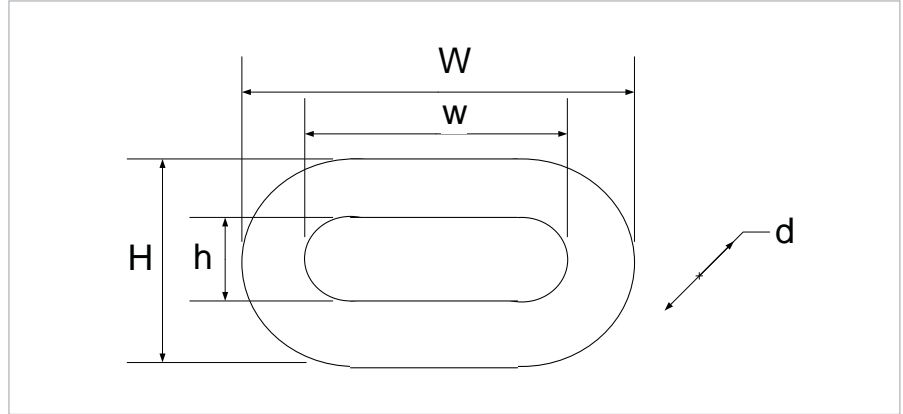

## Ordering numbers and dimensions

Ordering numbers for the core kits (2 cores per package) are given in the table below.

VLT® Frame Size	Danfoss ordering number	Core dimension [mm]					Weight [kg]	Packaging dimension [mm]
		W	w	H	h	d		
A and B	130B3257	60	43	40	25	22.3	0.25	190 x 100 x 70
C	130B3258	102	69	61	28	37	1.6	190 x 100 x 70
D	130B3259	189	143	126	80	37	2.45	235 x 190 x 140
E and F	130B3260	305	249	147	95	37	4.55	290 x 260 x 110

## Installation

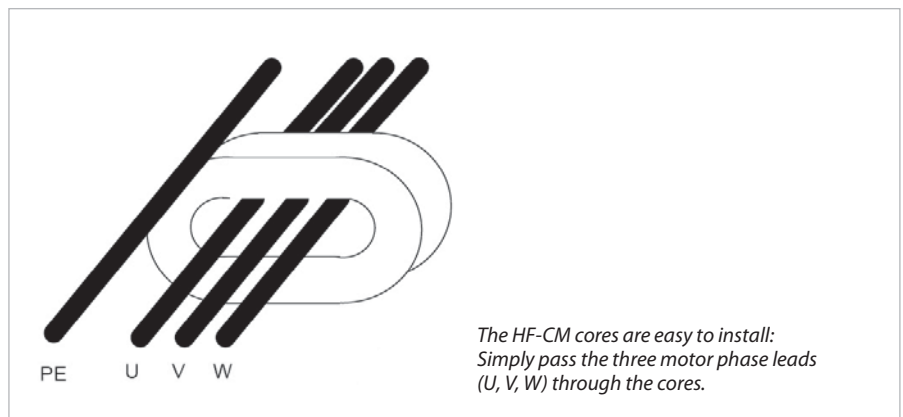

The HF-CM cores are easy to install: Simply pass the three motor phase leads (U, V, W) through the cores.

# VLT® Power Option Sine-wave Filter



## Perfect

### match for:

- Applications with older motors
- Aggressive environments
- Applications with frequent braking
- 690 V applications with general purpose motors
- Motor cable length above 150 metres

Sine-wave output filters are low-pass filters that suppress the switching frequency component from the drive and smooth out the phase-to-phase output voltage of the drive to become sinusoidal. This reduces the motor insulation stress and bearing currents.

Sine-wave output filters are low-pass filters that suppress the switching frequency component from the drive and smooth out the phase-to-phase output voltage of the drive to become sinusoidal. This reduces the motor insulation stress and bearing currents.

By supplying the motor with a sinusoidal voltage waveform, the switching acoustic noise from the motor is also eliminated.

### Thermal losses and bearing currents

The sinusoidal voltage supply to the motor reduces hysteresis thermal losses in the motor. Since the motor insulation lifetime is dependent on the motor temperature, the sine-wave filter prolongs the lifetime of the motor.

The sinusoidal motor terminal voltage from the sine-wave filter furthermore has the advantage of suppressing any bearing currents in the motor. This reduces the risk of flashover in the motor bearings and thereby also contributes to extended motor lifetime and increased service intervals.

### Feature

Supplies the motor with a sinusoidal voltage waveform

Eliminates over-voltages and voltage spikes caused by cable reflections

Reduces electromagnetic interference by eliminating pulse reflection caused by current ringing in the motor cable. This allows the use of unshielded motor cables in some applications.

Eliminates acoustic noise in motor

Reduces high frequent losses in motor

### Benefit

- Prevents flashover in motor windings

- Protects the motor insulation against premature aging

- Trouble-free operation

- Noiseless motor operation

- Prolongs service interval of motor

### Quality and Design

All filters are designed and tested for operation with the VLT® Automation-Drive FC 302, VLT® AQUA Drive FC 202, and the VLT® HVAC Drive FC 102. They are rated for the nominal switching frequency of the VLT® FC series and therefore no derating of the drive is needed.

The enclosure is designed to match the look and quality of the VLT® FC series drives.

### Advantages

- Compatible with all control principles including flux and VVC+
- Parallel filter installation is possible for applications in the high power range

### Range

3 x 200 – 500 V, 2,5 – 800 A

3 x 525 – 690 V, 13 – 660 A

### Enclosures

■ IP 00 and IP 20 wall-mounted enclosure up to 75 A (500 V)/13 A (690 V)

■ IP 23 floor-standing enclosure from 115 A (500 V)/28 A (690 V)

### Mounting

■ Side by side mount with the drive up to 75 A (500 V)

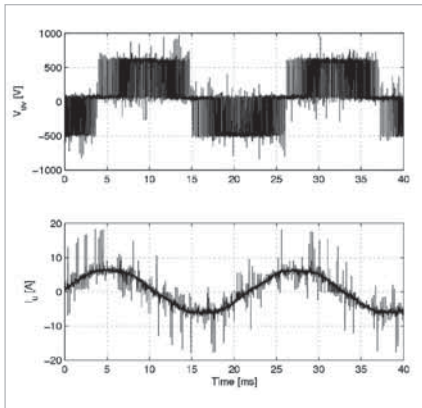

Voltage and current without filter

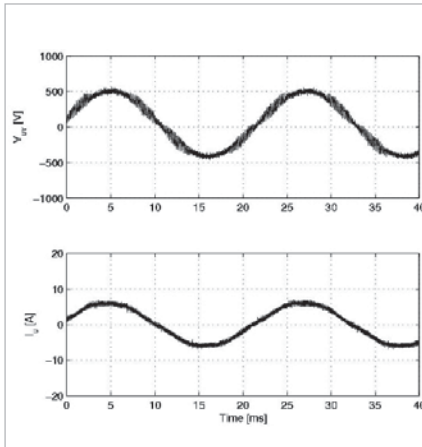

Voltage and current with filter

## Specifications

Voltage rating	3 x 200 – 500 V and 3 x 525 – 690 V
Nominal current I <sub>N</sub> @ 50 Hz	2.5 – 800A for higher power modules can be paralleled
Motor frequency	0 – 60 Hz without derating 100/120 Hz (up to 10 A) with derating
Ambient temperature	-25° to 45°C without derating
Min. switching frequency	f <sub>min</sub> 1,5 kHz – 5 kHz depending on filter type
Max. switching frequency	f <sub>max</sub> 8 kHz
Overload capacity	160% for 60 sec every 10 min.
Enclosure degree	IP 00/IP 20/IP 23 (ref. page 1)
Approvals	CE, UL508

## Relative sound pressure measurements from the motor with and without sine-wave filter

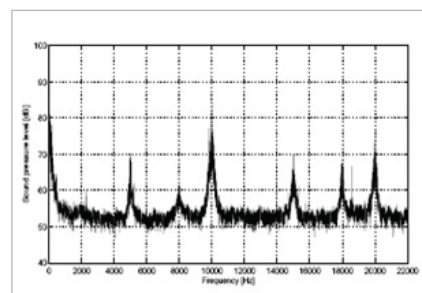

No filter

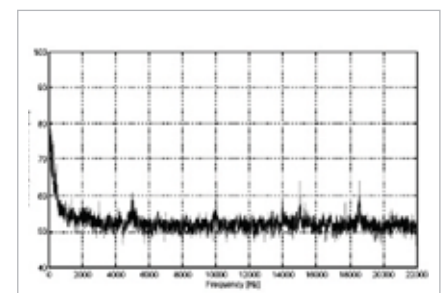

With sine-wave filter

Performance Criteria	du/dt filters	Sine-wave filters
<b>Motor insulation stress</b>	Up to 100 m cable (shielded/unshielded) complies with the requirements of IEC60034-17* (general purpose motors). Above this cable length the risk of "double pulsing" increases.	Provides a sinusoidal phase-to-phase motor terminal voltage. Complies with IEC-60034-17* and NEMA-MG1 requirements for general purpose motors with cables up to 500 m (1 km for frame size D and above).
<b>Motor bearing stress</b>	Slightly reduced, mainly in high power motors.	Reduces bearing currents caused by circulating currents. Does not reduce common-mode currents (shaft currents).
<b>EMC performance</b>	Eliminates motor cable ringing. Does not change the emission class. Does not allow longer motor cables as specified for the frequency converter's built-in RFI filter.	Eliminates motor cable ringing. Does not change the emission class. Does not allow longer motor cables as specified for the frequency converter's built-in RFI filter.
<b>Max. motor cable length</b>	100 m ... 150 m With guaranteed EMC performance: 150 m screened Without guaranteed EMC performance: 150 m unshielded	With guaranteed EMC performance: 150 m shielded and 300 m unshielded (only conducted emissions). Without guaranteed EMC performance: up to 500 m (1 km for frame size D and above).
<b>Acoustic motor switching noise</b>	Does not eliminate acoustic switching noise from the motor.	Eliminates acoustic switching noise from the motor caused by magnetostriction.
<b>Relative size</b>	15 – 50% (depending on power size).	100%
<b>Relative price</b>	50%	100%

\*Not 690 V

# VLT® Power Option dU/dt Filter



## Perfect

### match for:

- Applications with short motor cables (up to 150 m)
- Applications with older motors
- Aggressive environments
- Applications with frequent braking

dU/dt filters reduce the dU/dt values on the motor terminal phase-to-phase voltage – an issue that is important for short motor cables.

dU/dt filters are differential-mode filters which reduce motor terminal phase-to-phase peak voltages spikes and reduce the rise time to a level that lowers the stress on the insulation of motor windings.

Compared to sine-wave filters, the dU/dt filters have a cut-off frequency above the switching frequency. The voltage at the motor terminals is still PWM pulse shaped, but the rise time and  $U_{peak}$  are reduced. They are smaller, weigh less and have a lower price compared to sine-wave filters. Furthermore, because of the smaller inductance and capacitance, the dU/dt filters introduce a negligible reactance between inverter and motor and are therefore suitable for high dynamic applications.

### Superior compared to output chokes

Output chokes cause undamped oscillations at the motor terminals which increase the risk of double pulsing and over-voltages higher than twice the DC link voltage. The dU/dt filters are low-pass L-C filters with a well defined cut-off frequency. Therefore the ringing

### Feature

- Reduces dU/dt stresses
- Low voltage drop makes dU/dt filters the ideal solution for highly dynamic applications with flux vector regulation
- Lowers the magnetic interference propagation on surrounding cables and equipment

### Benefit

- Increases motor service interval
- Trouble-free operation
- Small size and cost compared to sine-wave filters

oscillations at the motor terminals are damped and there is a reduced risk of double pulsing and voltage peaks.

### Quality and Design

All dU/dt filters are designed and tested for operation with the VLT® AutomationDrive FC 302, VLT® AQUA Drive FC 202, and the VLT® HVAC Drive FC 102. They are designed to match the look and quality of the VLT® FC series drives.

### Advantages

- Compatible with all control principles, including flux and WC+
- Parallel filter installation is possible for applications in the high power range

### Range

3 x 200 – 690 V (up to 880 A)

### Enclosures

- IP 00 and IP 20/23 enclosure in the entire power range.
- IP 54 enclosure available up to 180 A.

### Mounting

- Side by side mounting with the drive
- Filters wall mounted up to 480 A (380 V) and floor mounted above that size

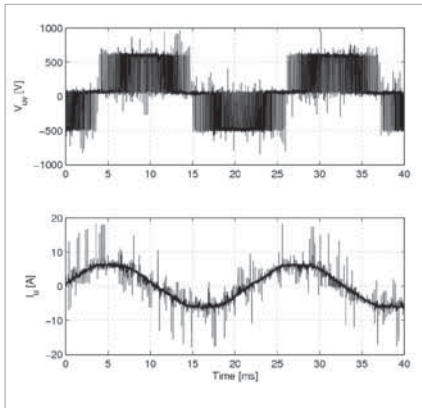

Voltage and current without filter

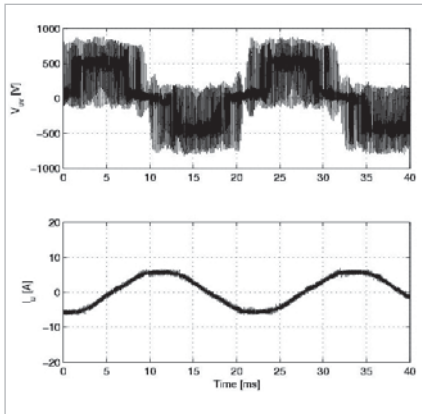

Voltage and current with filter

## Specifications

Voltage rating	3 x 200 – 690 V
Nominal current $I_N$ @ 50 Hz	44 – 880 A @ 200 – 380 V, 40 – 780 A @ 460 V 32 – 630 A @ 600 V and 27 – 630 A @ 690 V for higher power modules can be paralleled
Motor frequency	0 – 60 Hz without derating Max. 100 Hz (with derating)
Ambient temperature	-25° to 45° C without derating
Max. switching frequency	$f_{sw}$ 1,5 kHz – 4 kHz depending on filter type
Mounting	Side-by-side
Overload capacity	160% for 60 sec every 10 min.
Enclosure degree	IP 00, IP 20/23 and IP 54
Approvals	CE, UL508

## dU/dt limit curves

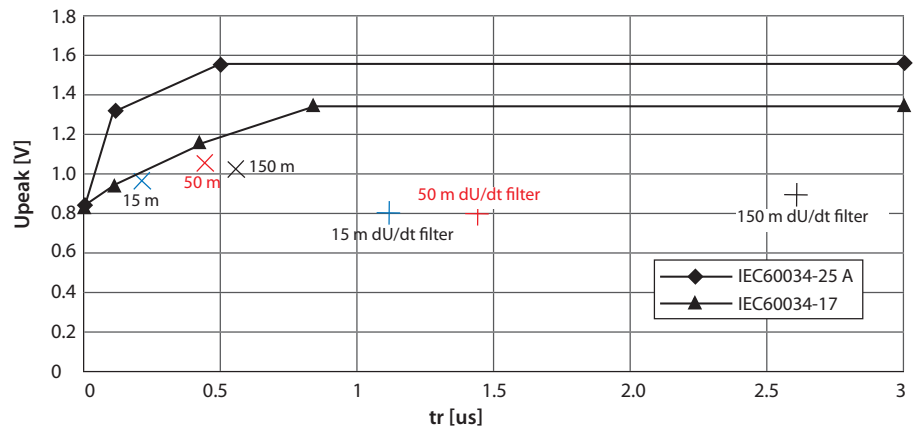

The dU/dt value decreases with the motor cable length whereas the peak voltage increases. Therefore it is recommended to use sine-wave filters in installations with motor cable lengths above 150 m.

Performance Criteria	du/dt filters	Sine-wave filters
<b>Motor insulation stress</b>	Up to 100 m cable (shielded/unshielded) complies with the requirements of IEC60034-17* (general purpose motors). Above this cable length the risk of "double pulsing" increases.	Provides a sinusoidal phase-to-phase motor terminal voltage. Complies with IEC-60034-17* and NEMA-MG1 requirements for general purpose motors with cables up to 500 m (1 km for frame size D and above).
<b>Motor bearing stress</b>	Slightly reduced, mainly in high power motors.	Reduces bearing currents caused by circulating currents. Does not reduce common-mode currents (shaft currents).
<b>EMC performance</b>	Eliminates motor cable ringing. Does not change the emission class. Does not allow longer motor cables as specified for the frequency converter's built-in RFI filter.	Eliminates motor cable ringing. Does not change the emission class. Does not allow longer motor cables as specified for the frequency converter's built-in RFI filter.
<b>Max. motor cable length</b>	100 m ... 150 m With guaranteed EMC performance: 150 m screened Without guaranteed EMC performance: 150 m unshielded	With guaranteed EMC performance: 150 m shielded and 300 m unshielded (only conducted emissions). Without guaranteed EMC performance: up to 500 m (1 km for frame size D and above).
<b>Acoustic motor switching noise</b>	Does not eliminate acoustic switching noise from the motor.	Eliminates acoustic switching noise from the motor caused by magnetostriction.
<b>Relative size</b>	15 – 50% (depending on power size).	100%
<b>Relative price</b>	50%	100%

\*Not 690 V

# VLT® Motion Control Tool MCT 10

## Perfect

tool for:

- Commissioning
- Servicing
- Programming

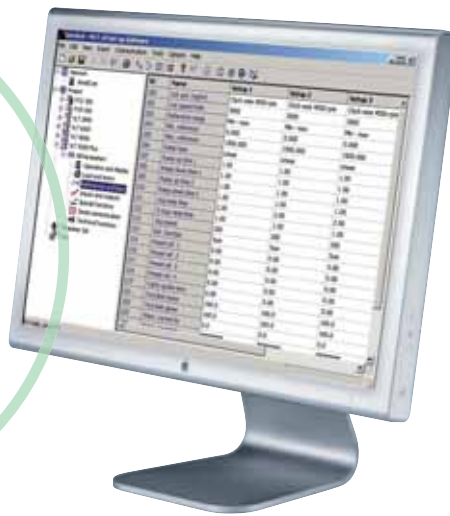

The VLT® Motion Control Tool, MCT 10, is ideal for commissioning and servicing the drive including guided programming of cascade controller, real-time clock, smart logic controller and preventive maintenance.

The setup software provides easy control of details as well as a general overview of systems, large or small. The tool handles all drive series, VLT® Advanced Active Filters and VLT® Soft Starter related data.

### More efficient service organization

- Scope & logging: analyse problems easily
- Read out alarms, warnings and fault log in one view.
- Compare saved project with on-line drive
- Update drive or option firmware. One tool handling all *(to be supported in January)*

### More efficient commissioning

- Off-line commissioning off site
- Save/send/mail projects anywhere
- Easy field-bus handling, multiple drives in project file. Enables service organization to be more efficient

Feature	Benefit
One PC tool for all tasks	Save time
"Explorer-like" view	Easy to use
Option programming	Save time
Online and offline commissioning	Flexible and save cost
Scope & logging	Easy and fast analyzing – less downtime
Alarm history	Easy fault finding
Multiple interfaces	Easy connection
USB connection	Easy connection
Flexible Ethernet connection	Easy connection – save time (utilizing all Danfoss Ethernet based fieldbus options)

### Basic version

- Off –line commissioning (max. 4 drives)
- Scope & Graph (max. 2 channels)
- Multiple fieldbus support
- Alarm history in saved projects
- MCO 305 support
- Graphical Smart Logic Controller
- Graphical Clock functions, Time-based Actions, Preventive Maintenance and Basic Cascade Controller (FC 102/FC 202 only)
- Update drive support to support new firmware (future compatible)
- FC drive conversion (FC 102/FC 202 & FC 300 series)

### Advanced version

- Basic version functionality +
- No limitation in number of drives
- Scope & Graph (max. 8 channels)
- Real Time Logging from drive
- Motor Database
- Graphical Sensorless pump control
- Graphical Extended Cascade Controller (FC-202 only)
- Full Customer Specific Initialization File support *(to be supported in January)*
- Full drive password protection support *(To be supported in January)*

## Fieldbuses

- Profibus DP-V1
- RS485
- USB
- Ethernet-TSC

## Internet download

<http://www.danfoss.com/drives>

## System requirements

- MS Windows® NT 4.0, 2000, XP, Vista or 7
- Pentium III 350 MHz or better
- 512 MB RAM or better
- 200 MB free hard disk space
- CD-ROM drive
- VGA or XGA graphic adapter

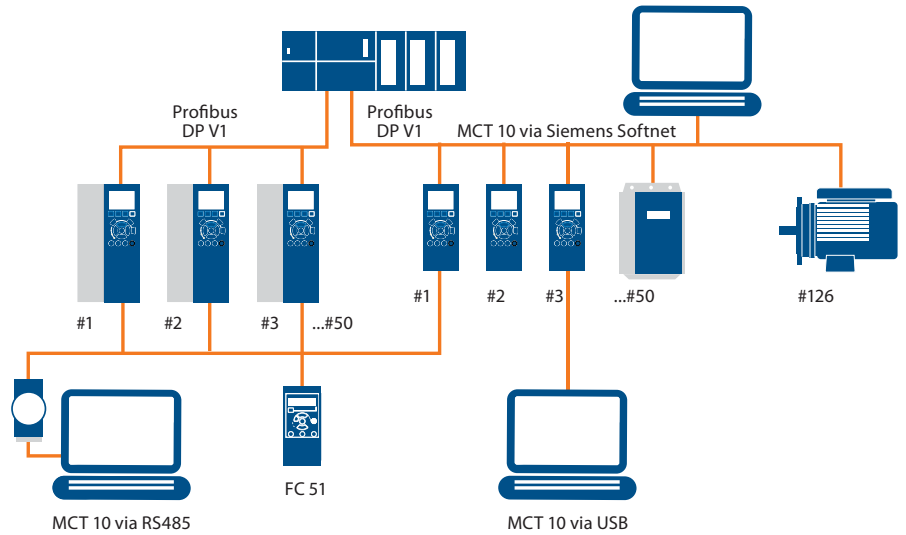

# VLT® MCT 31 Harmonics Calculation Software

## Perfect

tool for:

- Application specific simulations
- Various Power Supply sources
- Norm compliance indication
- Project Documentation



With VLT® MCT 31, you can determine whether harmonics will be an issue in your installation when drives are added. VLT® MCT 31 estimates the benefits of adding various harmonic mitigation solutions from the Danfoss product portfolio and calculates system harmonic distortion.

### Save money and reduce running costs

On the basis that it is better to avoid a problem rather than cure one after it happens, it is preferable to calculate the effect of installing non-linear loads before doing so, to estimate the degree of harmonic distortion that may result.

Trying to achieve this on a spreadsheet basis can be time consuming and inaccurate.

To help, Danfoss offers free to download, the VLT® Harmonic Calculation Tool MCT 31, a simple to use and fast software tool for calculating the harmonic disruption from your existing or intended drives installation.

A fast estimate is vital as, in this case, more is not better, simply more costly, so the MCT 31 can help save money when selecting harmonic mitigation solutions.

Simply over-specifying a harmonic mitigation solution will lead to unnecessary initial cost escalation and increased running expenses.

Feature	Benefit
Explore-like view	Easy to use
Simple simulation model with less parameters	Easy to use and fast simulation – save time
Configurable for various Power supply sources	Matching all customer needs
One tool supporting all Danfoss harmonic mitigation solutions	Matching all customer needs
Configurable Norm compliance indication	Save time
User configurable Report gation solutions	Project documentation
Simulate the setup before installation	Save time and money. Prevent problems appear later

### Calculate the harmonic disturbance

The MCT 31 tool can easily be used to evaluate the expected grid quality and includes a range of passive and active counter-measures which can be selected to ease system stress.

The power quality impact of electronic devices can be estimated in the frequency range up to 2.5 kHz, depending on the system configuration and standard limits.

The analysis includes indication of compliance with various standards and recommendations.

The Windows-like interface of the MCT 31 tool makes possible intuitive

operation of the software. It is built with a focus on user-friendliness and the complexity is limited to system parameters that are normally accessible.

The Danfoss VLT® frequency converter and mitigation equipment data is already pre-loaded, allowing fast data entry.

Your local Danfoss consultant will be very happy to provide all the assistance you need to evaluate your power quality and advice in the selection of the correct mitigation for your circumstances.

## Internet download

<http://www.danfoss.com/drives>

## System requirements

- MS Windows NT 4.0, 2000, XP, Vista or 7
- Pentium III 350 MHz or better
- 512 MB RAM or better
- 200 MB free hard disk space
- CD-ROM drive
- VGA or XGA graphic adapter

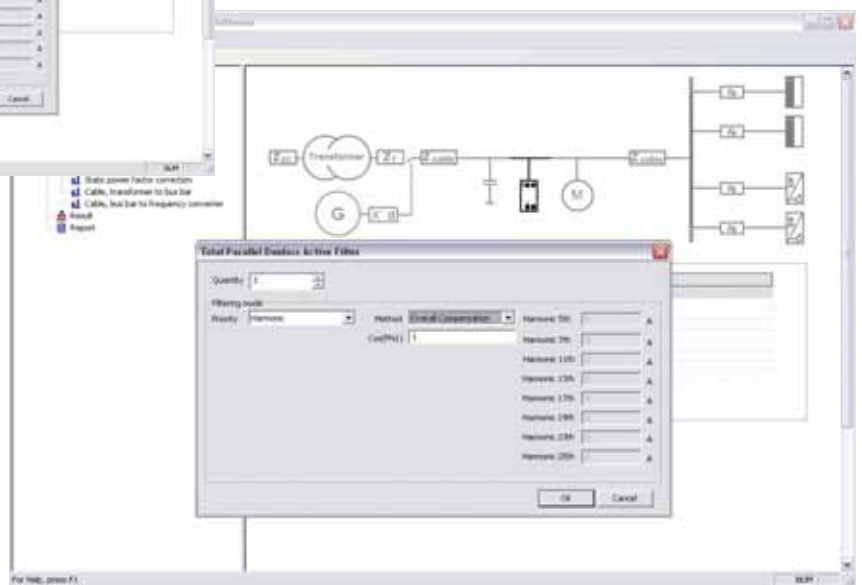
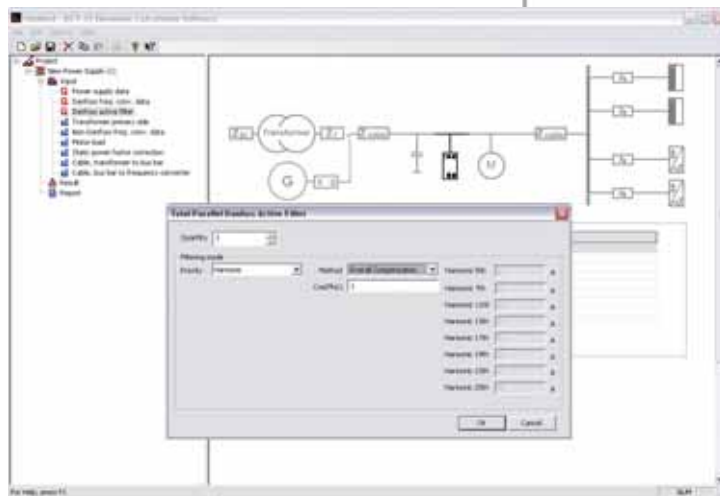
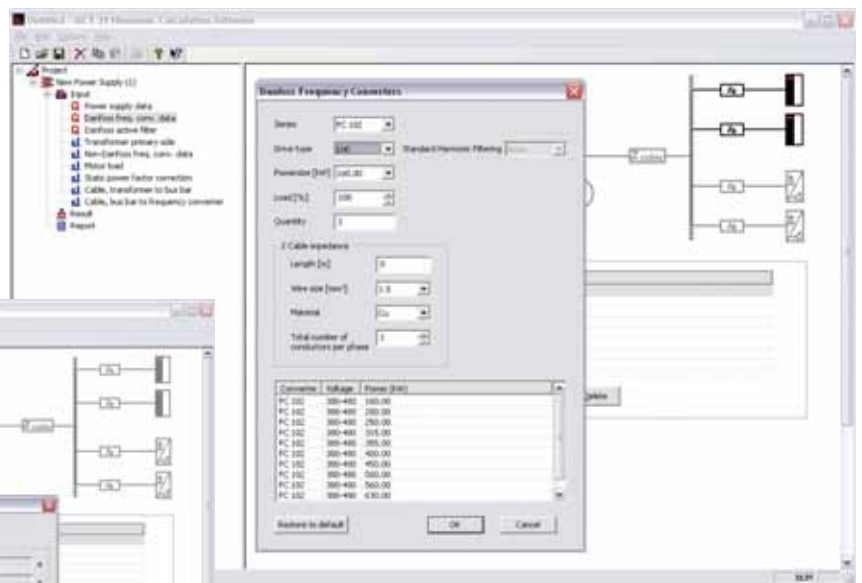
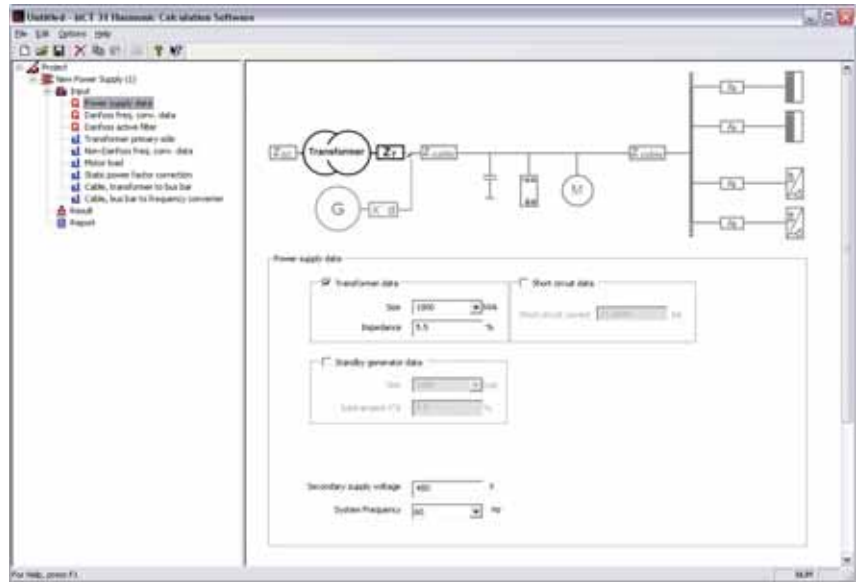

# VLT® Energy Box

## Perfect

tool for:

- Designing HVAC installations
- Obtaining energy savings
- Calculating pay-back time



With VLT® Energy Box software you can both theoretically in project face estimate and afterwards physically validate your real energy savings and reductions in your carbon footprint – from your desk.

VLT® Energy Box makes energy consumption calculations of fan, pump and cooling tower applications driven by VLT® HVAC Drives from Danfoss and compares it with alternative methods of flow control.

The program compares the total operation costs of various traditional systems compared to operation of the same system with a VLT® HVAC Drive.

With VLT® Energy Box software you can both theoretically in project face estimate and afterwards physically validate your real energy savings and reductions in your carbon footprint – also from your desk.

The VLT® Energy Box communicates with the drives through the USB/RS485 protocol and can read all data about duty cycles and energy consumptions.

Data about duty cycles and energy consumptions can be requested remotely from the VLT® HVAC Drive, making it easy to monitor your energy savings and return on investment. Monitoring via fieldbus often makes energy meters ommissible.

### Feature

- Estimate savings
- Calculates pay back based on investments and annual costs
- Generates a report
- Special cooling tower mode based on climate data
- Possible to adjust climate region to local conditions
- Download of energy data from the drive via serial communication and USB
- Covers several projects and systems in same file

### Benefit

- Make purchase decision easy
- Economical overview
- Easy communication
- Easy calculation
- More accurate calculations
- Facilitates the drives payback function
- Visualize actual load profile
- Generation of common project report

The software allows you to upload real trend and energy data, to present multiple systems in one report and to calculate energy consumption for cooling towers.

### Complete financial analysis

VLT® Energy Box provides a complete financial analysis including:

- Initial cost for the drive system and the alternative system
- Installation and hardware costs
- Annual maintenance costs and any utility company incentives for installation of energy conservation products
- Payback time and accumulated savings are calculated

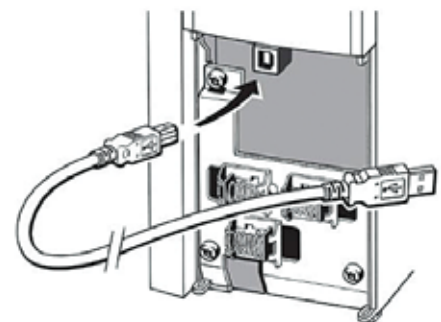

### No nonsense

Since VLT® Energy Box both estimates and afterwards measures the real energy savings, it is a very trustworthy means for calculating projects involving many fans, pumps and cooling towers. You can simply install a single VLT® HVAC Drive and check the actual savings to exactly calculate the benefits from installing VLT® HVAC Drives on the other applications.

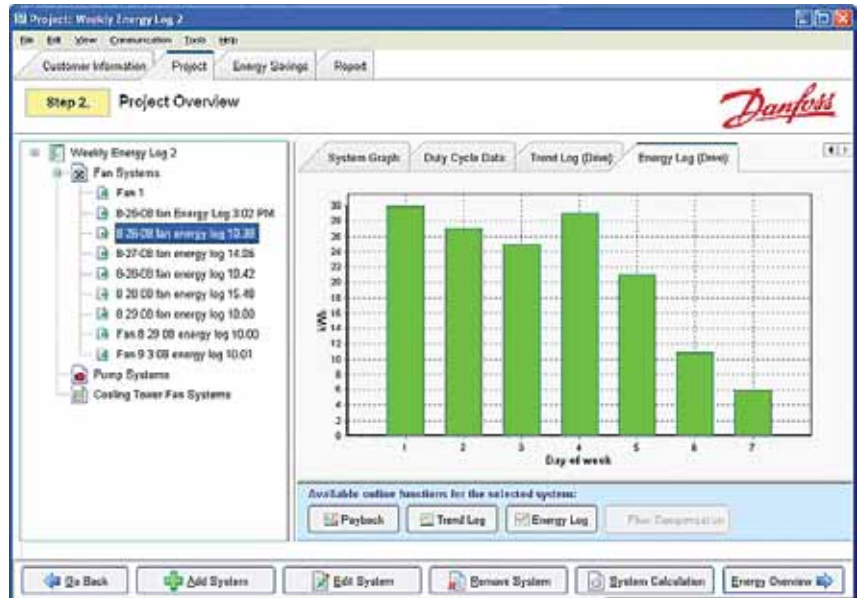

### Considers local conditions

VLT® Energy Box use local weather data in its calculations for cooling towers.

Data from weather zones around the Globe are pre-installed, but the user is free to adjust these data according to local conditions.



### Specify the curve

Energy Box offers an advanced mode to specify the fan or pump curve in more detail.

The fan or pump (equipment) curve can be adjusted to match almost any shape.

Choose flow and pressure points to generate an equipment curve similar to the published fan or pump curve over the relevant section of the curve using the mechanical flow control method.

The program will not allow calculations in regions that are in a surge region or beyond the end of the curve.

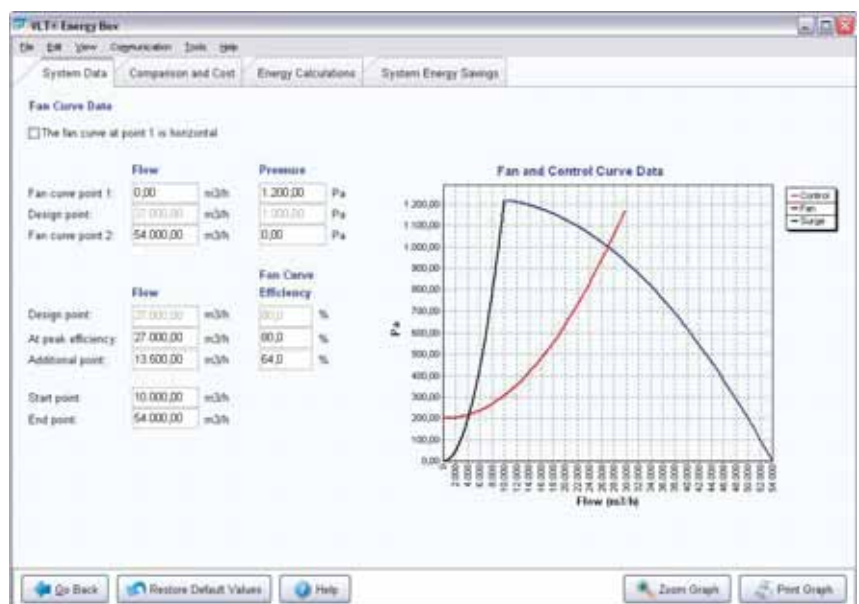



# VLT® Service

## VLT® DrivePro™

### LifeCycle Service Packages

Plus, Premium and Supreme

## Service you can rely on 24/7 – around the world

### Sales and Service

Contacts worldwide. Helping to optimise your productivity, improve your maintenance, and control your finances.

- 24/7 availability
- Local hotlines, local language and local stock

The Danfoss service organisation is present in more than 100 countries – ready to respond whenever and wherever you need, around the clock, 7 days a week.

Find your local expert team on [www.danfoss.com/drives](http://www.danfoss.com/drives)

**24 hours**  
7 days a week

### VLT® DrivePro™ Plus

The Plus Package offers a program of support to help customers realize improve drive availability and reliability.

#### Features

- Preventative Maintenance
- Standard Training
- 24 hour Hotline
- 24 hour response time
- On-site service

### VLT® DrivePro™ Premium

Our Premium Program provides a combination of basic and advanced service and support resources aimed at extending the life of your drives and ensure peak economic performance.

#### Features

- Preventative Maintenance
- Standard and scheduled training
- 24 hour Hotline
- 6 hour response time
- On-site service, inc. labour & travel
- Start-up
- Extended warranty – Depot
- Extended warranty – On-site
- Environmental disposal

### VLT® DrivePro™ Supreme

The Supreme Package provides a full scope of service to meet your operational needs, help you achieve business critical KPI metrics and last but not least give you total peace of mind.

#### Features

- Preventative Maintenance
- Customer-specific training
- 24 hour Hotline
- 6 hour response time
- On-site service, inc. labour & travel
- Start-up
- Extended warranty – Depot
- Extended warranty – On-site
- Environmental disposal
- Analysis and surveys
- Spare Parts/Drives
- SmartStep
- Stock Maintenance & Consignment
- Stock

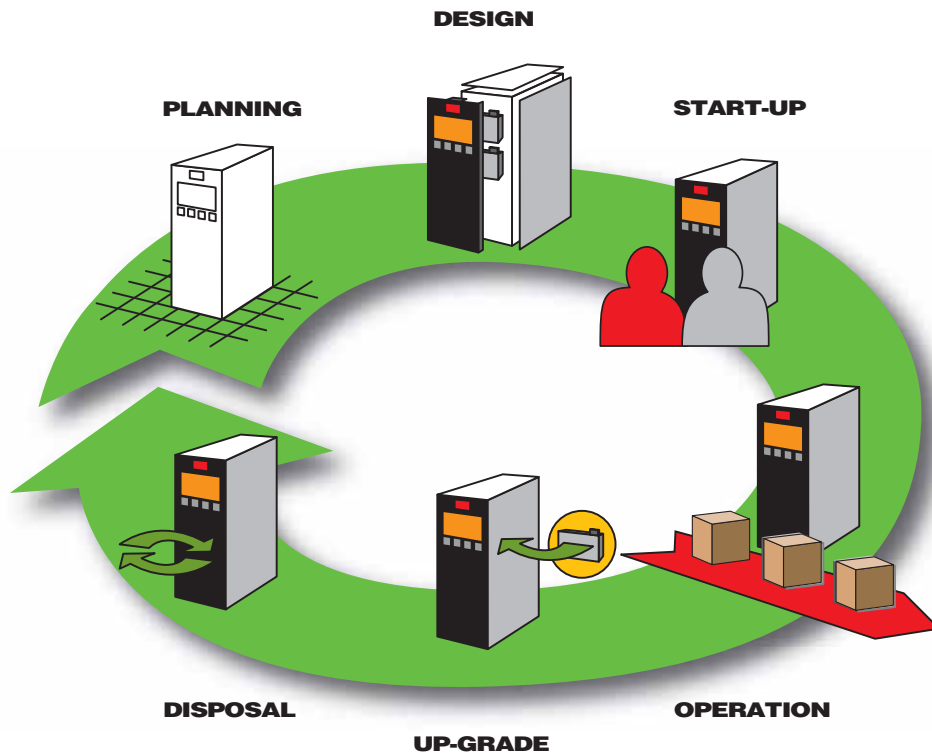

# VLT® DrivePro™ SmartStep

Upgrade and replace equipment proactively for total peace of mind

## Upgrade sensibly

DrivePro™ SmartStep is a comprehensive replacement and upgrade program for customers to assure optimal efficiency and cost performance. It's an easy upgrade program for substantially reduced cost that's backed by professional service support.

## DrivePro™ SmartStep advantages

- Customized service and upgrade program
- Flexible replacement plan
- Fixed costs

## Designed for success

- Minimize down-time costs
- Extend mean-time-to-repair intervals
- Control your maintenance budget
- Avoid unexpected investments in equipment

## Available for application areas such as:

- Food & Beverage
- HVAC
- CTM (chemical, textile, materials)
- Water and wastewater





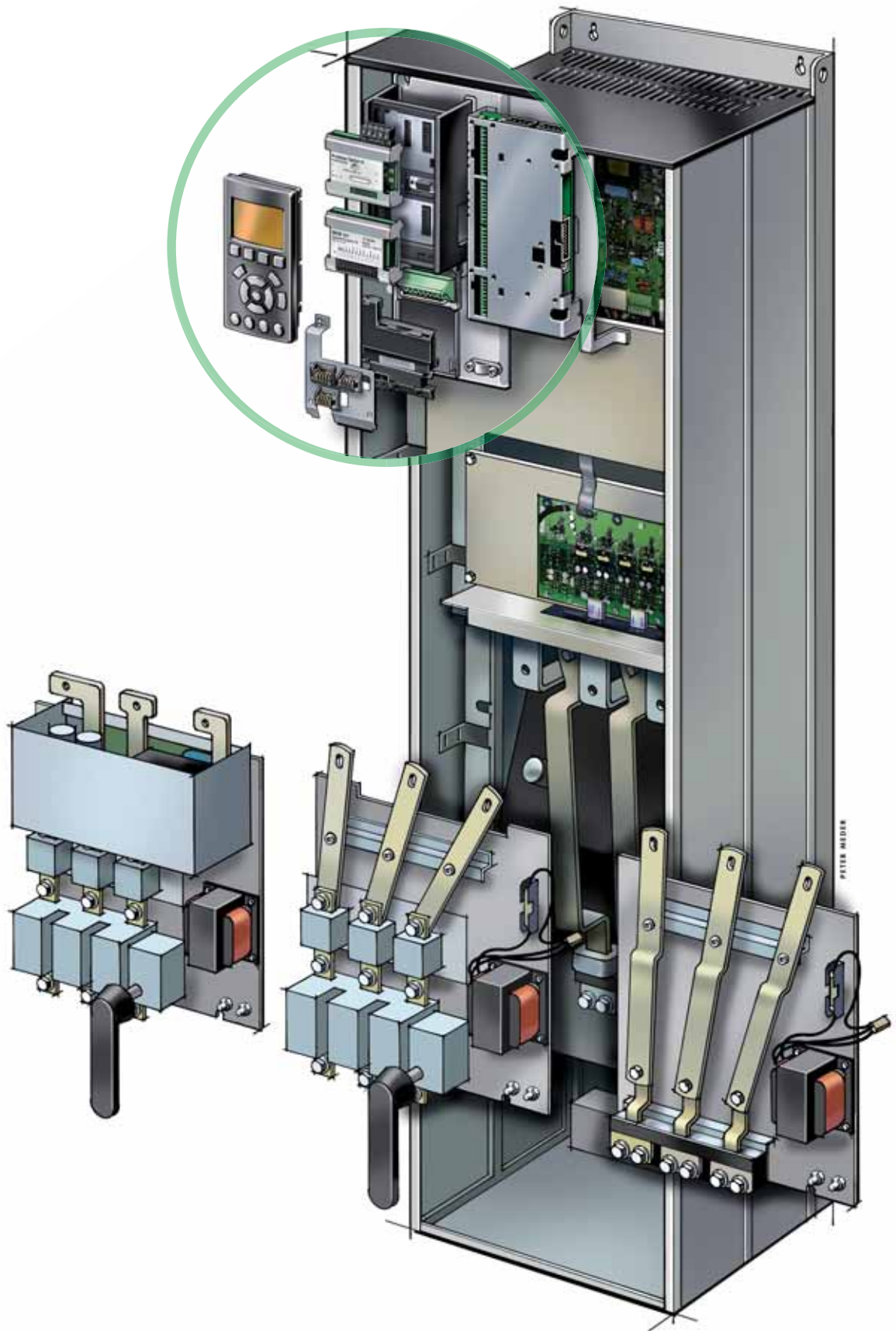



# What VLT<sup>®</sup> is all about

Danfoss VLT Drives is the world leader among dedicated drives providers – and still gaining market share.

## Environmentally responsible

VLT<sup>®</sup> products are manufactured with respect for the safety and well-being of people and the environment.

All activities are planned and performed taking into account the individual employee, the work environment and the external environment. Production takes place with a minimum of noise, smoke or other pollution and environmentally safe disposal of the products is pre-prepared.

### UN Global Compact

Danfoss has signed the UN Global Compact on social and environmental responsibility and our companies act responsibly towards local societies.

### EU Directives

All factories are certified according to ISO 14001 standard. All products fulfil the EU Directives for General Product Safety and the Machinery directive. Danfoss VLT Drives is, in all product series, implementing the EU Directive concerning Hazardous Substances in Electrical and Electronic Equipment (RoHS) and is designing all new product series according to the EU Directive on Waste Electrical and Electronic Equipment (WEEE).

### Impact on energy savings

One year's energy savings from our annual production of VLT<sup>®</sup> drives will save the energy equivalent to the energy production from a major power plant. Better process control at the same time improves product quality and reduces waste and wear on equipment.

## Dedicated to drives

Dedication has been a key word since 1968, when Danfoss introduced the world's first mass produced variable speed drive for AC motors – and named it VLT<sup>®</sup>.

Twenty five hundred employees develop, manufacture, sell and service drives and soft starters in more than one hundred countries, focused only on drives and soft starters.

## Intelligent and innovative

Developers at Danfoss VLT Drives have fully adopted modular principles in development as well as design, production and configuration.

Tomorrow's features are developed in parallel using dedicated technology platforms. This allows the development of all elements to take place in parallel, at the same time reducing time to market and ensuring that customers always enjoy the benefits of the latest features.

## Rely on the experts

We take responsibility for every element of our products. The fact that we develop and produce our own features, hardware, software, power modules, printed circuit boards, and accessories is your guarantee of reliable products.

## Local backup – globally

VLT<sup>®</sup> motor controllers are operating in applications all over the world and Danfoss VLT Drives' experts located in more than 100 countries are ready to support our customers with application advice and service wherever they may be.

Danfoss VLT Drives experts don't stop until the customer's drive challenges are solved.

